

# STR-DE485/DE485E

## SERVICE MANUAL

Ver 1.0 2002.02



Photo: STR-DE485

US Model  
Canadian Model  
E Model  
Australian Model  
Chinese Model  
STR-DE485  
AEP Model  
UK Model  
STR-DE485E

Manufactured under license from Dolby Laboratories. "Dolby", "Pro Logic" and the double-D symbol are trademarks of Dolby Laboratories. "DTS" and "DTS Digital Surround" are registered trademarks of Digital Theater Systems, Inc.

### SPECIFICATIONS

#### AUDIO POWER SPECIFICATIONS

##### POWER OUTPUT AND TOTAL HARMONIC DISTORTION:

With 8 ohm loads, both channels driven, from 40 – 20,000 Hz; rated 80 watts per channel minimum RMS power, with no more than 0.09 % total harmonic distortion from 250 milliwatts to rated output (STR-DE485 area code US only).

##### Amplifier section

###### POWER OUTPUT

Models of area code US, CND  
Rated Power Output at Stereo Mode  
(8 ohms 40 Hz – 20 kHz, THD 0.09 %)  
STR-DE485: 80 W + 80 W

Reference Power Output  
(8 ohms 1 kHz, THD 0.7 %)  
STR-DE485: FRONT <sup>1)</sup>: 80 W/ch  
CENTER <sup>1)</sup>: 80 W  
SURR <sup>1)</sup>: 80 W/ch

Models of area code AEP, UK  
Rated Power Output at Stereo Mode  
(8 ohms 1 kHz, THD 0.7 %)  
STR-DE485E 80 W + 80 W<sup>2)</sup>

Reference Power Output  
(8 ohms 1 kHz, THD 0.7 %)  
STR-DE485E FRONT <sup>1)</sup>: 80 W/ch  
CENTER <sup>1)</sup>: 80 W  
SURR <sup>1)</sup>: 80 W/ch

Models of other area code  
Rated Power Output at Stereo Mode  
(8 ohms 1 kHz, THD 0.7 %)  
80 W + 80 W<sup>2)</sup>

Reference Power Output<sup>2)</sup>  
(8 ohms 1 kHz, THD 10 %)  
FRONT <sup>1)</sup>: 100 W/ch  
CENTER <sup>1)</sup>: 100 W  
SURR <sup>1)</sup>: 100 W/ch

1) Depending on the sound field settings and the source, there may be no sound output.

2) Measured under the following conditions:

Area code	Power requirements
E, AUS	240 V AC, 50 Hz
SP, AEP, UK	230 V AC, 50 Hz
TW	110 V AC, 60 Hz
MX	120 V AC, 60 Hz

###### Frequency response

MULTI CH IN (STR-DE485 only), CD, MD/TAPE, DVD/LD, VIDEO 1, 2	10 Hz – 50 kHz +0.5/-2 dB (with sound field, and tone bypassed)
--	---

###### Inputs (Analog)

MULTI CH IN (STR-DE485 only), CD, MD/TAPE, DVD/LD, VIDEO 1, 2	Sensitivity: 250 mV Impedance: 50 kilohms S/N <sup>3)</sup> : 96 dB (A, 250 mV <sup>4)</sup> )
--	---

3) INPUT SHORT (with sound field and tone bypassed).

4) Weighted network, input level.

– Continued on next page –

## FM STEREO/FM-AM RECEIVER

9-873-587-01  
2002B0400-1  
© 2002.02

Sony Corporation  
Home Audio Company  
Published by Sony Engineering Corporation

# SONY®

# STR-DE485/DE485E

## Inputs (Digital)

DVD/LD (Coaxial)	Sensitivity: – Impedance: 75 ohms S/N: 100 dB (A, 20 kHz LPF)
VIDEO 2 (Optical)	Sensitivity: – Impedance: – S/N: 100 dB (A, 20 kHz LPF)

## Outputs

MD/TAPE (REC OUT), VIDEO1 (AUDIO OUT)	Voltage: 250 mV Impedance: 10 kilohms
SUB WOOFER	Voltage: 2 V Impedance: 1 kilohms

## Tone

Gain levels: ±6 dB, 1 dB step

## FM tuner section

Tuning range	87.5 - 108.0 MHz
Antenna terminals	75 ohms, unbalanced
Intermediate Frequency	10.7 MHz
Sensitivity	
Mono:	18.3 dBf, 2.2 µV/75 ohms
Stereo:	38.3 dBf, 22.5 µV/75 ohms
Usable sensitivity	11.2 dBf, 1 µV/75 ohms
S/N	
Mono:	76 dB
Stereo:	70 dB
Harmonic distortion at 1 kHz	
Mono:	0.3%
Stereo:	0.5%
Separation	45 dB at 1 kHz
Frequency response	30 Hz – 15 kHz, +0.5/-2 dB
Selectivity	60 dB at 400 kHz

## AM tuner section

### Tuning range

Models of area code US, CND  
With 10-kHz tuning scale: 530 – 1710 kHz<sup>5)</sup>  
With 9-kHz tuning scale: 531 – 1710 kHz<sup>5)</sup>

Models of area code E2, MX  
With 10-kHz tuning scale: 530 – 1610 kHz<sup>5)</sup>  
With 9-kHz tuning scale: 531 – 1602 kHz<sup>5)</sup>

Models of area code AUS, SP, AEP, UK, TW  
With 9-kHz tuning scale: 531 – 1602 kHz

Antenna	Loop antenna
Intermediate Frequency	450 kHz
Usable sensitivity	50 dB/m (at 1,000 kHz or 999 kHz)
S/N	54 dB (at 50 mV/m)
Harmonic distortion	0.5 % (50 mV/m, 400 Hz)
Selectivity	
At 9 kHz:	35 dB
At 10 kHz:	40 dB

5) You can change the AM tuning scale to 9 kHz or 10 kHz. After tuning in any AM station, turn off the receiver. Hold down PRESET TUNING + and press I/⏪. All preset stations will be erased when you change the tuning scale. To reset the scale to 10 kHz (or 9 kHz), repeat the procedure.

## Video section

Inputs	
Video:	1 V <sub>p-p</sub> , 75 ohms
Outputs	
Video:	1 V <sub>p-p</sub> , 75 ohms

## General

### Power requirements

Area code	Power requirements
US, CND, MX	120 V AC, 60 Hz
AEP, UK	230 V AC, 50/60 Hz
SP	220 – 230 V AC, 50/60 Hz
E	120/220/240 V AC, 50/60 Hz
TW	110 V AC, 50/60 Hz
AUS	240 V AC, 50Hz

### Power consumption

Area code	Power consumption
US, MX	STR-DE485: 180 W
CND	STR-DE485: 260 VA
AEP, UK	STR-DE485E: 155 W
AUS, SP, E	STR-DE485: 155 W
TW	STR-DE485: 400 W

### Power consumption (during standby mode)

0.5 W

Dimensions  
430 × 145 × 298 mm  
(16 7/8 × 5 6/8 × 11 6/8 in.)  
including projecting parts  
and controls

Mass (Approx.) 7.0 kg (15lb 7 oz)

### Supplied accessories

- FM wire antenna (1)
- AM loop antenna (1)
- STR-DE485E/DE485 only
- Remote commander RM-U306 (1)
- R6 (size-AA) batteries (2)

Design and specifications are subject to change without notice.

### • Abbreviation

CND	: Canadian model
AR	: Argentina model
AUS	: Australian model
CH	: Chinese model
MX	: Mexican model
SP	: Singapore model
TW	: Taiwan model

**SAFETY CHECK-OUT**

After correcting the original service problem, perform the following safety check before releasing the set to the customer:

Check the antenna terminals, metal trim, "metallized" knobs, screws, and all other exposed metal parts for AC leakage.

Check leakage as described below.

**LEAKAGE TEST**

The AC leakage from any exposed metal part to earth ground and from all exposed metal parts to any exposed metal part having a return to chassis, must not exceed 0.5 mA (500 microamperes.). Leakage current can be measured by any one of three methods.

1. A commercial leakage tester, such as the Simpson 229 or RCA WT-540A. Follow the manufacturers' instructions to use these instruments.
2. A battery-operated AC milliammeter. The Data Precision 245 digital multimeter is suitable for this job.
3. Measuring the voltage drop across a resistor by means of a VOM or battery-operated AC voltmeter. The "limit" indication is 0.75 V, so analog meters must have an accurate low-voltage scale. The Simpson 250 and Sanwa SH-63Trd are examples of a passive VOM that is suitable. Nearly all battery operated digital multimeters that have a 2 V AC range are suitable. (See Fig. A)

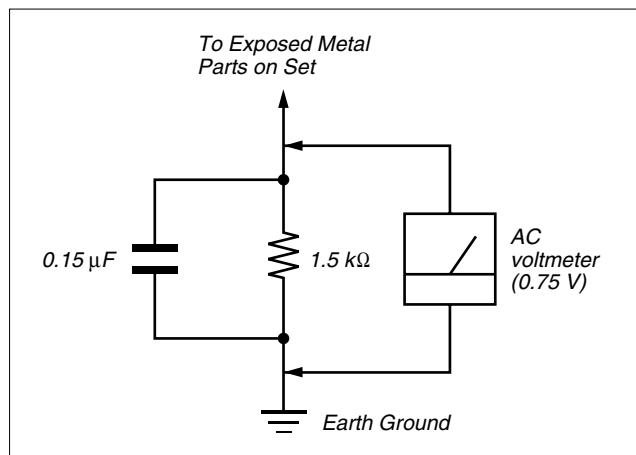
**SAFETY-RELATED COMPONENT WARNING!!**

COMPONENTS IDENTIFIED BY MARK  $\triangle$  OR DOTTED LINE WITH MARK  $\triangle$  ON THE SCHEMATIC DIAGRAMS AND IN THE PARTS LIST ARE CRITICAL TO SAFE OPERATION. REPLACE THESE COMPONENTS WITH SONY PARTS WHOSE PART NUMBERS APPEAR AS SHOWN IN THIS MANUAL OR IN SUPPLEMENTS PUBLISHED BY SONY.

**MODEL IDENTIFICATION**

— BACK PANEL —

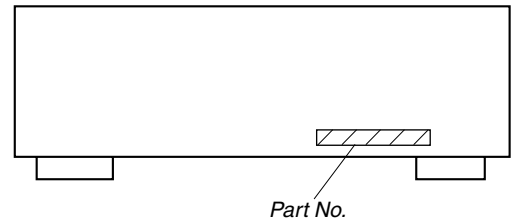

MODEL	PART No.
US	4-238-188-0□
Canadian	4-238-188-1□
Australian	4-238-188-2□
Singapore	4-238-188-3□
Chinese	4-238-188-4□
E	4-238-188-5□
AEP	4-238-188-6□
UK	4-238-188-7□
Mexican	4-238-188-8□
Argentina	4-238-188-9□
Taiwan	4-238-189-9□

**ATTENTION AU COMPOSANT AYANT RAPPORT À LA SÉCURITÉ!!**

LES COMPOSANTS IDENTIFIÉS PAR UNE MARQUE  $\triangle$  SUR LES DIAGRAMMES SCHÉMATIQUES ET LA LISTE DES PIÈCES SONT CRITIQUES POUR LA SÉCURITÉ DE FONCTIONNEMENT. NE REMPLACER CES COMPOSANTS QUE PAR DES PIÈCES SONY DONT LES NUMÉROS SONT DONNÉS DANS CE MANUEL OU DANS LES SUPPLÉMENTS PUBLIÉS PAR SONY.

**与安全有关的零部件须知**

在原理图上用阴影及  $\triangle$  标记来识别的零部件在安全操作上是具有关键性的。这些零部件要用本手册中所示的部件号对应的索尼零部件进行更换。

在安全操作上具有关键性的电路调整与索尼公司出版的维修手册完全一致。在更换关键零部件时或怀疑动作失常时，请进行这些调整操作。

## TABLE OF CONTENTS

### 1. GENERAL

Main unit .....	5
Remote button description .....	6

### 2. DISASSEMBLY

2-1. Case .....	7
2-2. Front Panel Section .....	8
2-3. Back Panel .....	8
2-4. Digital Board .....	9
2-5. Standby Board .....	9
2-6. Main Board .....	10

### 3. TEST MODE ..... 11

### 4. DIAGRAMS

4-1. IC Pin Description .....	12
4-2. Circuit Boards Location .....	15
4-3. Block Diagram – Tuner/Audio Section – .....	16
4-4. Block Diagram – Digital Section – .....	17
4-5. Block Diagram – Video/Display Section – .....	18
4-6. Block Diagram – Power Section – .....	19
4-7. Printed Wiring Boards – Main Section – .....	21
4-8. Schematic Diagram – Main Section (1/2) – .....	22
4-9. Schematic Diagram – Main Section (2/2) – .....	23
4-10. Printed Wiring Board – Digital Section (1/2) – .....	24
4-11. Printed Wiring Board – Digital Section (2/2) – .....	25
4-12. Schematic Diagram – Digital Section (1/2) – .....	26
4-13. Schematic Diagram – Digital Section (2/2) – .....	27
4-14. Printed Wiring Board – Video Section – .....	28
4-15. Schematic Diagram – Video Section – .....	29
4-16. Printed Wiring Boards – Display Section – .....	30
4-17. Schematic Diagram – Display Section – .....	31
4-18. Printed Wiring Boards – Power Section – .....	32
4-19. Schematic Diagram – Power Section – .....	33
4-20. IC Block Diagrams .....	34

### 5. EXPLODED VIEWS

5-1. Case Section .....	35
5-2. Front Panel Section .....	36
5-3. Chassis Section-1 .....	37
5-4. Chassis Section-2 .....	38

### 6. ELECTRICAL PARTS LIST ..... 39

# SECTION 1 GENERAL

This section is extracted from instruction manual.

## List of Button Locations and Reference Pages

**How to use this page**  
Use this page to find the location of buttons that are mentioned in the text.

	Illustration number
NAME	8 (35)
Name of button/part	Reference page

### Main unit

**ALPHABETICAL ORDER**

**0 - 9**

2 CH 26 (25)

**A - D**

A.DEC 28 (23-25)

AM (Except for models of area code CEL, CEK) 32 (30, 31)

BASS +/- 25 (29, 54)

CD 19 (21)

CINEMA STUDIO EX A, B, C 9 (23, 24)

Digital Cinema Sound (indicator) 12 (23)

DIMMER 37 (22)

DISPLAY 2 (22, 33, 51)

Display 11 (22)

DVD/LD 21 (21)

**E - L**

ENTER 29 (35)

FM (Except for models of area code CEL, CEK) 33 (30, 31)

FM/AM (Models of area code CEL, CEK only) 32 (30, 31)

FM MODE (Models of area code CEL, CEK only) 33, (Except for models of area code CEL, CEK) 34 (31)

INPUT MODE 15 (21)

IR (receptor) 4 (38, 45, 51)

LEVEL 10 (20, 27, 55)

**M**

MASTER VOLUME 23 (20, 49)

MD/TAPE 17 (21)

MEMORY 36 (30, 32)

MENU +/- 30 (16, 27, 35, 36)

MENU </> 31 (16, 27, 35, 36)

MODE 27 (24, 50)

MULTI CHANNEL DECODING (indicator) (Except for STR-DE485E) 7 (21)

MULTI CH IN (Except for STR-DE485E) 14 (21)

MUTING 24 (21, 49)

**N - S**

NAME 8 (35)

PHONES (jack) 38 (21)

PRESET/PTY SELECT +/- (Models of area code CEL, CEK only) 3 (32, 33)

PRESET TUNING +/- (Except for models of area code CEL, CEK) 3 (32, 53)

PTY (Models of area code CEL, CEK only) 34 (33)

SET UP 6 (4, 16, 36, 54)

SHIFT 35 (32)

SLEEP (STR-DE485E only) 14 (36)

SURR 13 (27, 54)

**T - Z**

TREBLE +/- 16 (29, 54)

TUNER 22 (21, 30-32, 35)

TUNING +/- 5 (31)

VIDEO 1 18 (21)

VIDEO 2 20 (21)

**BUTTON DESCRIPTIONS**

I/O (power) 1 (4, 15, 20, 29, 30, 53)

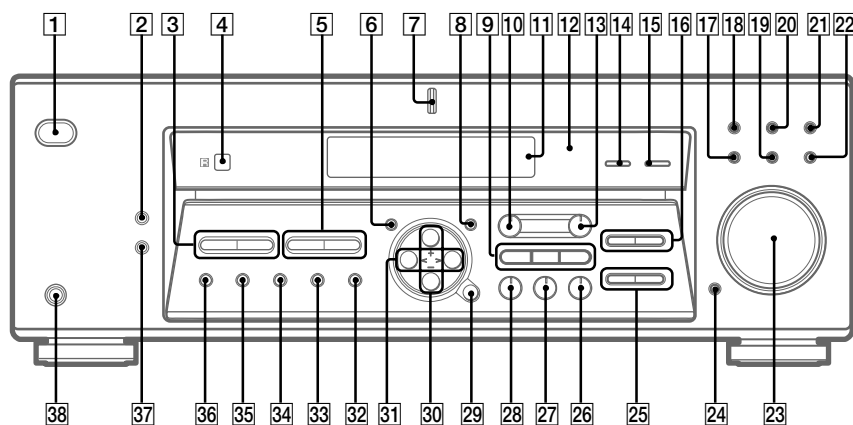

List of Button Locations and Reference Pages

5 GB

**Operations Using the Remote RM-U306**

**Except for STR-DE585 area code CA**

You can use the remote RM-U306 to operate the components in your system.

**Remote button description**

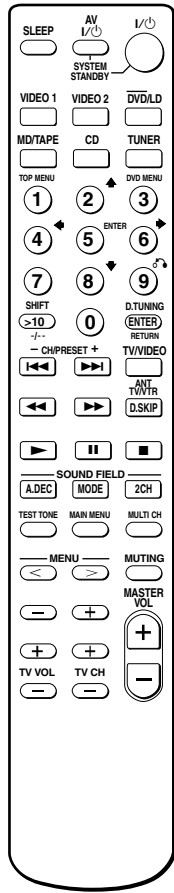

The tables below show the settings of each button.

Remote Button	Operations	Function
SLEEP	Receiver	Activates the sleep function and the duration which the receiver turns off automatically.
I/O	Receiver	Turns the receiver on or off.

**continued**

45<sup>GB</sup>

**Remote button description (continued)**

Remote Button	Operations	Function
VIDEO 1	Receiver	To watch VCR. (VTR mode 3)
VIDEO 2	Receiver	To watch VCR. (VTR mode 1)
DVD/LD	Receiver	To watch DVD or laser disc.
MD/TAPE	Receiver	To listen to Minidisc or audio tape.
CD	Receiver	To listen to compact disc.
TUNER	Receiver	To listen to radio programs.
SHIFT	Receiver	Press repeatedly to select a memory page for presetting radio stations or tuning to preset stations.
D.TUNING	Receiver	Tuner station direct key-in-mode.
A.DEC	Receiver	Select AUTO DECODE mode.
MODE	Receiver	Selects sound field mode.
2CH	Receiver	Selects 2CH mode.
TEST TONE	Receiver	Press to output test tone.
MAIN MENU	Receiver	Press this button repeatedly to select one of the four cursor modes: SURR, LEVEL, SET UP and NAME.
MULTI CH	Receiver	Selects MULTI CH IN source.
MENU </>	Receiver	Selects a menu item.
MENU +/-	Receiver	Makes adjustment or change the setting.
MUTING	Receiver	Mutes the sound from the receiver.

Operations Using the Remote RM-U306

46<sup>GB</sup>

## SECTION 2 DISASSEMBLY

**Note :** This set can be disassemble according to the following sequence.

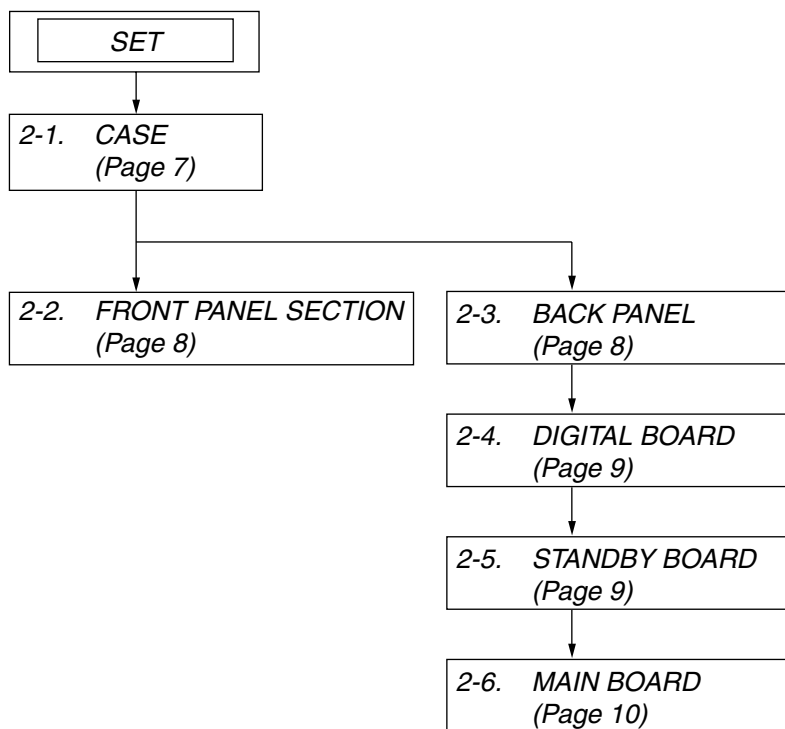

**Note :** Follow the disassembly procedure in the numerical order given.

### 2-1. CASE

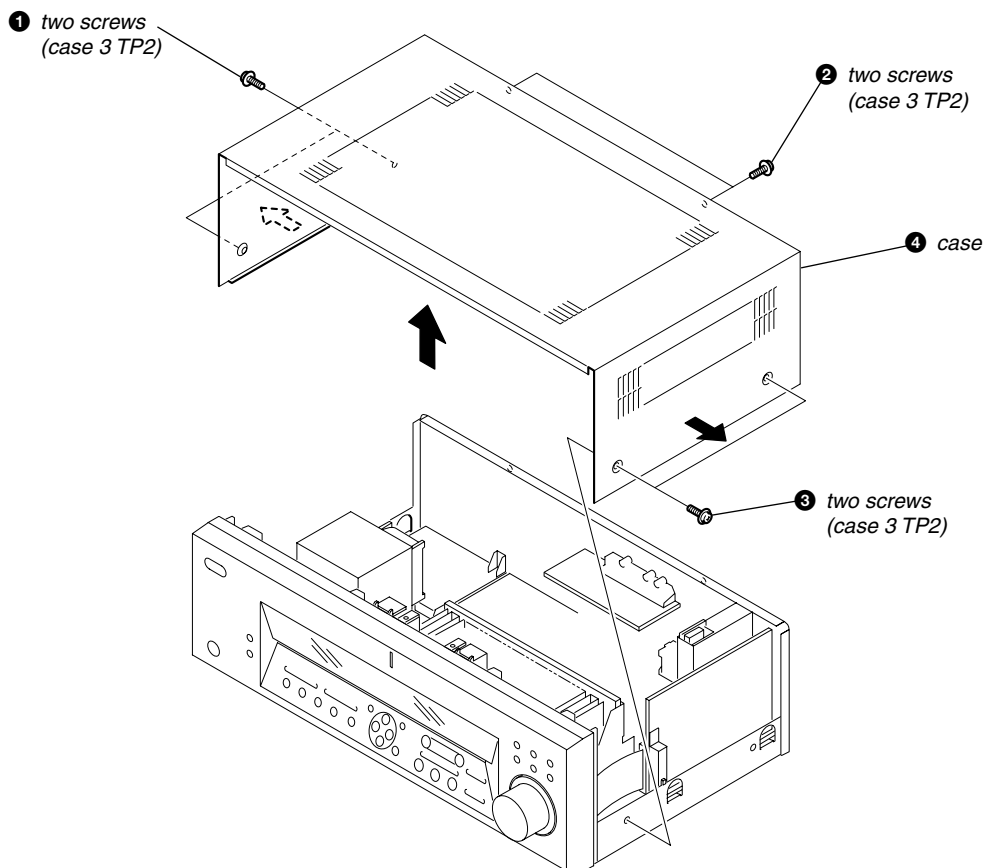

2-2. FRONT PANEL SECTION

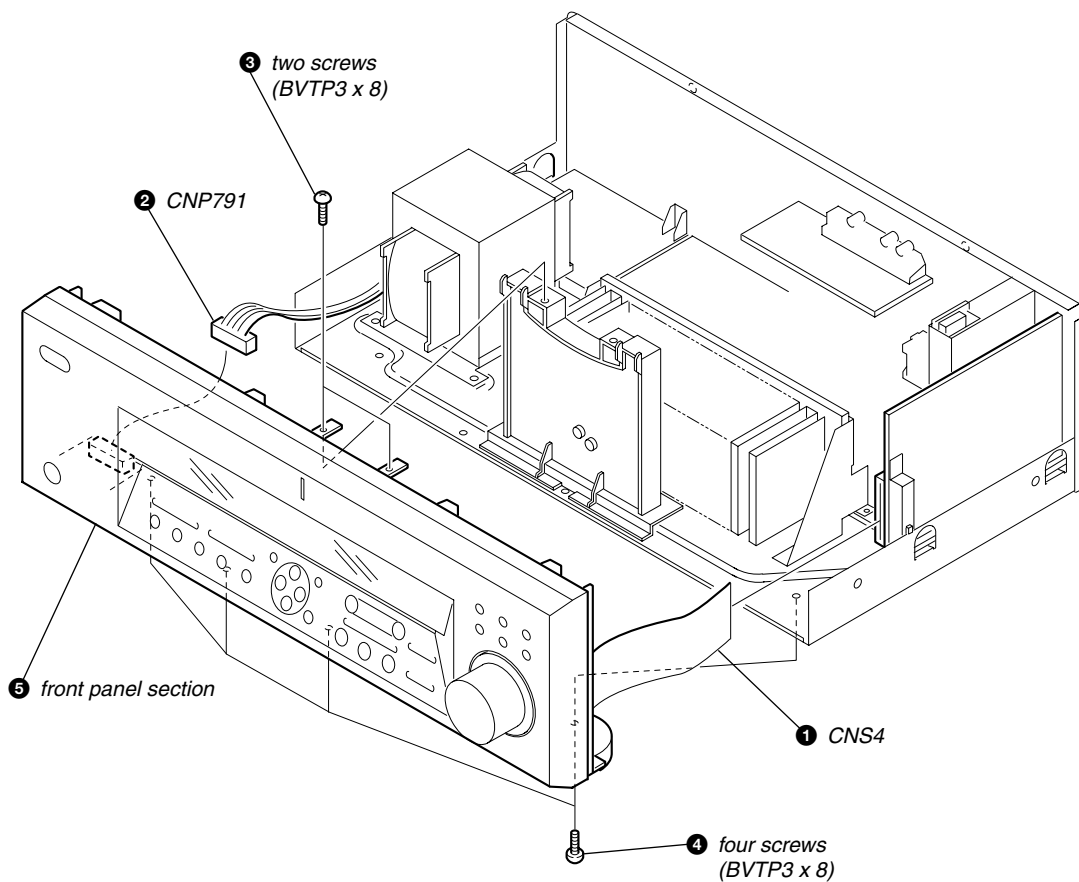

2-3. BACK PANEL

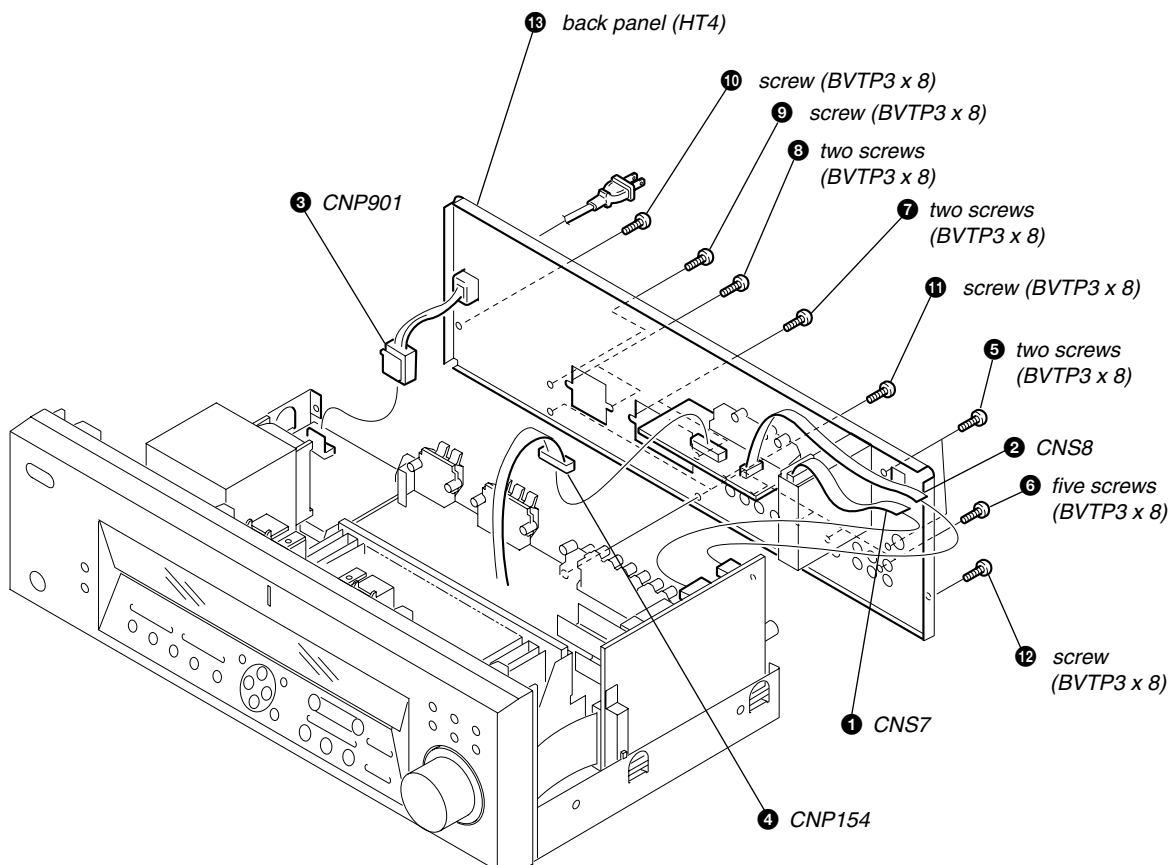



2-4. DIGITAL BOARD

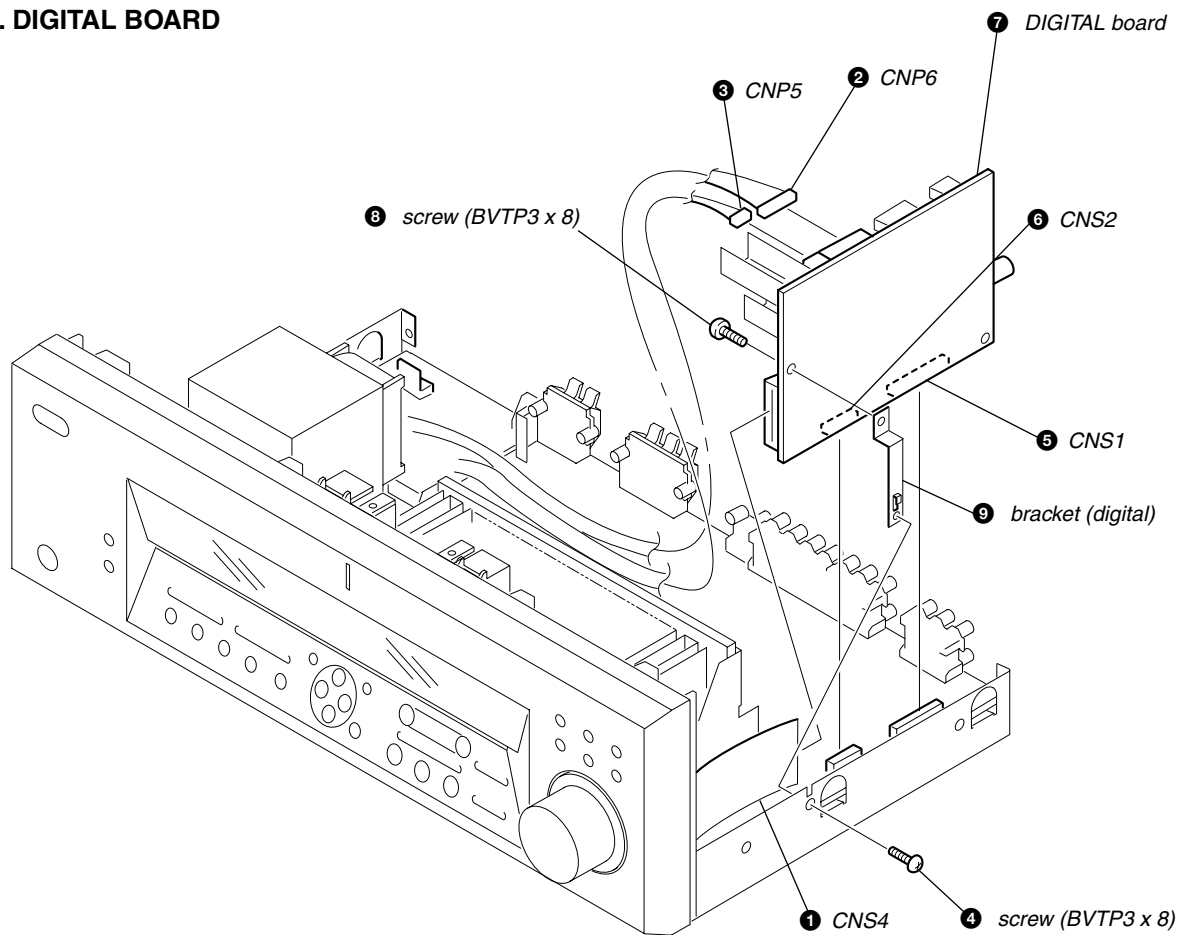

2-5. STANDBY BOARD

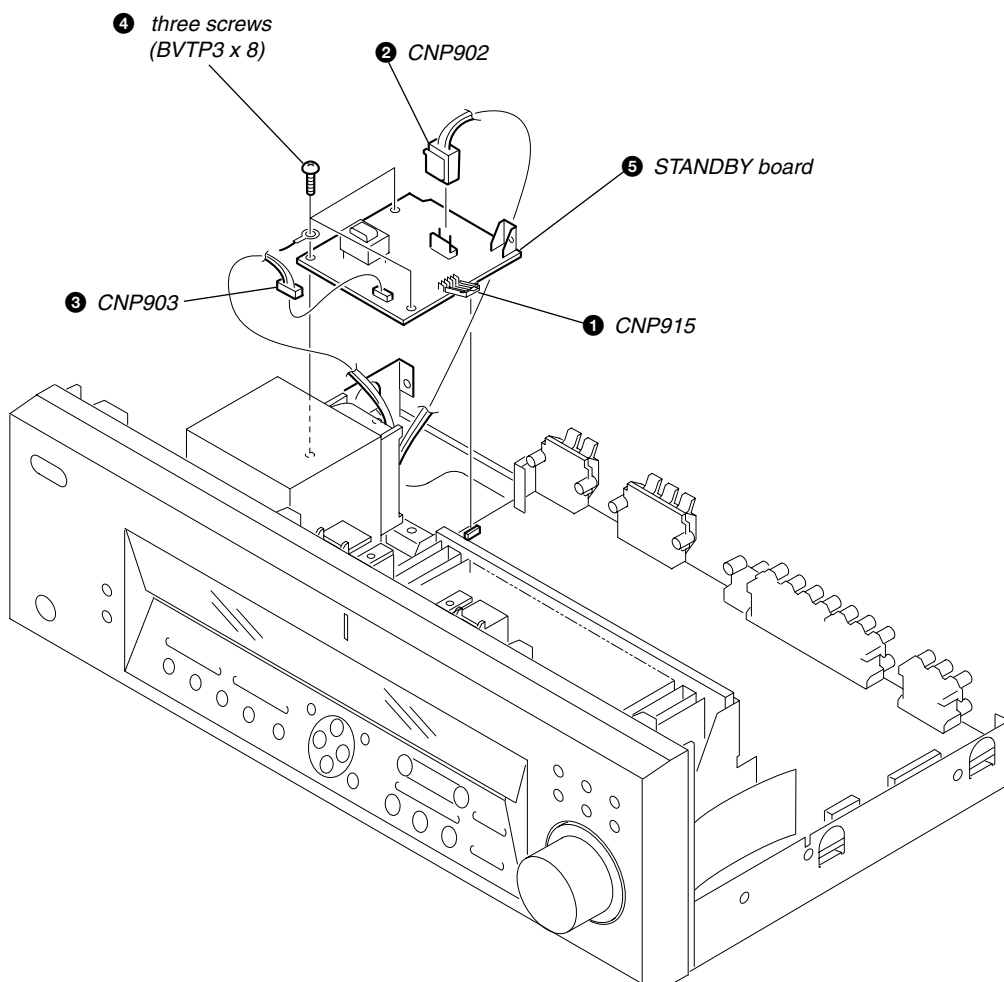

2-6. MAIN BOARD

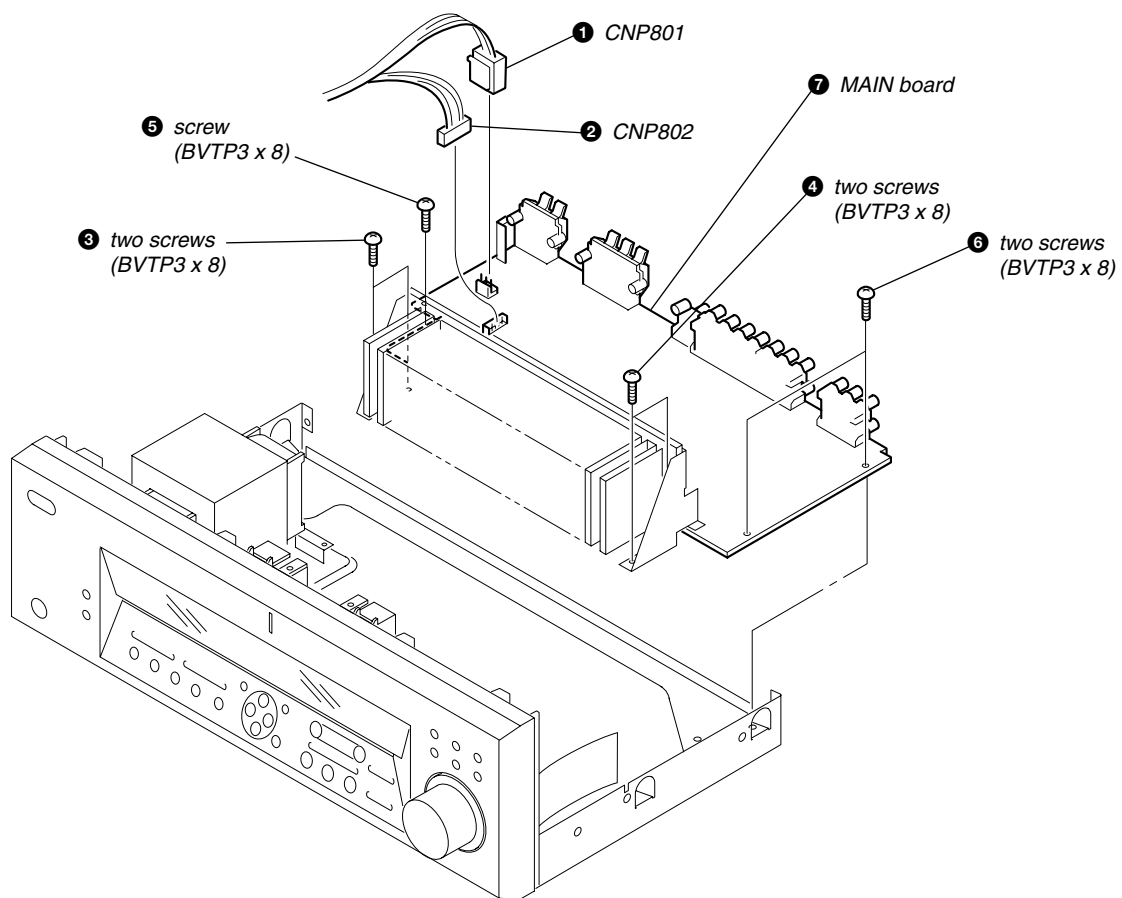

## SECTION 3 TEST MODE

### SOFTWARE VERSION DISPLAY MODE

\* The software version is displayed.

\* Procedure:

While depressing the **[ENTER]** and the SOUND FIELD **[A.F.D.]** buttons simultaneously, press the power **[I/⏻]** button to turn on the main power. The model name, destination and the software version are displayed.

### FLUORESCENT INDICATOR TUBE TEST MODE

\* All fluorescent segments are tested. When this test is activated, all segments turn on at the same time, then each segment turns on one after another.

\* Procedure:

While depressing the **[MD/TAPE]** and the **[SHIFT]** buttons simultaneously, press the power **[I/⏻]** button to turn on the main power.

1. All segments turn on.



**[MULTI CHANNEL DECODING]**, **[Digital Cinema Sound]**, SOUND FIELD **[A.F.D.]**, **[MODE]**, **[2CH]** and **[SET UP]** LED turn on.

2. Press the **[VIDEO 1]** button, confirm display

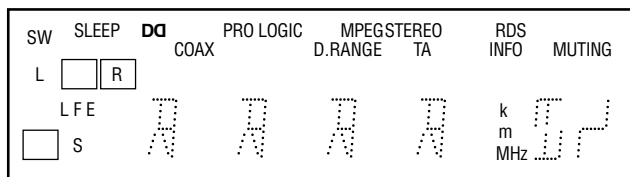

SOUND FIELD **[A.F.D.]**, **[MODE]**, SOUND CONTROL **[LEVEL]**, **[SET UP]** and **[Digital Cinema Sound]** LED turn on.

3. Press the **[VIDEO 1]** button, confirm display

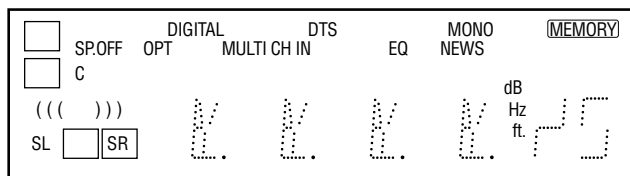

**[MULTI CHANNEL DECODING]**, SOUND FIELD **[2CH]**, SOUND CONTROL **[SURR]** and **[NAME]** LED turn on.

4. Press the **[VIDEO 1]** button, All segments turn off.

5. Every pressing of the **[VIDEO 1]** button turns on each segment and LED one after another in the same order.

(Not only the **[VIDEO 1]** button, but also the other buttons such as **[VIDEO 2]**, **[DVD/LD]**, **[MD/TAPE]**, **[CD]**, **[TUNER]** can be used.)

### FACTORY PRESET MODE

\* All preset contents are reset to the default setting.

\* Procedure:

While depressing the **[VIDEO 1]** and the SOUND FIELD **[2CH]** buttons simultaneously, press the power **[I/⏻]** button to turn on the main power. The message FACTORY appears and switch off the set.

While depressing the **[VIDEO 1]** and the SOUND FIELD **[2CH]** buttons simultaneously, press the power **[I/⏻]** button again. The message FACTORY appears and the preset contents are reset to the default values.

### SOUND FIELD CLEAR MODE

\* The preset sound field is cleared when this mode is activated.

Use this mode before returning the product to clients upon completion of repair.

\* Procedure:

While depressing the SOUND FIELD **[MODE]** button, press the power **[I/⏻]** button to turn on the main power. The message S. F. CLR appears and initialization is performed.

### AM CHANNEL STEP 9 kHz/10 kHz SELECTION MODE

\* Either the 9 kHz step or 10 kHz step can be selected for the AM channel step.

\* Procedure:

Set the **[TUNER]** to **[AM]**. Turn off the main power.

While depressing the **[TUNING+]** button or the **[PRESET TUNING-]** button, press the power **[I/⏻]** button to turn on the main power. Either the message 9 k STEP or 10 k STEP appears. Select the desired step.

\* For US/E model only

### KEY CHECK MODE

\* Button check

\* Procedure:

While depressing the **[VIDEO 1]** and the **[SHIFT]** buttons simultaneously, press the power **[I/⏻]** button to turn on the main power. "REST 39" appears.

Every pressing of any button other than the **[I/⏻]**, **[TREBLE+, -]** and the **[BASS+, -]** counts down the buttons. The buttons which are already counted once are not counted again. When all buttons are pressed "REST 04" appears.

When **[MASTER VOLUME]** is rotated in clockwise direction, "VOL MIN", "VOL 1" to "VOL 73", "VOL MAX" appear.

## SECTION 4 DIAGRAMS

### 4-1. IC PIN DESCRIPTION

#### • IC1201 CXD9617R (DSP) (DIGITAL Board (1/2))

Pin No.	Pin Name	I/O	Description
1	VSS	—	Ground
2	XRST	I	Reset signal input
3	EXTIN	I	Not used (connected to ground)
4	FS2	I	Not used (connected to ground)
5	VDDI	I	Power supply
6	FS1	I	Not used (connected to ground)
7	PLOCK	O	Internal PLL lock signal output (Not used)
8	VSS	—	Ground
9	MCLK1	I	Clock signal input (13.5 MHz)
10	VDDI	I	Power supply
11	VSS	—	Ground
12	MCLK2	O	Clock signal output (13.5 MHz)
13	MS	I	Switching of master/slave operation L : internal clock, H : EXTIN clock is used
14	SCKOUT	O	Internal system clock signal output
15	LRCKI1	I	Not used (open)
16	VDDE	I	Power supply
17	BCKI1	I	Not used (open)
18	SDI1	I	Audio IF data input
19	LRCKO	O	Sampling clock output for digital audio serial data
20	BCKO	O	Bit clock output terminal for digital audio serial data
21	VSS	—	Ground
22	KFSIO	I/O	Audio clock signal (364fs/256fs) input/output
23 to 25	SDO1 to SDO3	O	Digital audio serial data output
26	SDO4	O	Audio IF serial output (Not used) (open)
27	SPDIF	O	Not used (open)
28	LRCKI2	I	Sampling clock input for audio serial data
29	BCKI2	I	Bit clock input terminal for audio serial data
30	SDI2	I	Digital audio data input
31	VSS	—	Ground
32	HACN	O	Acknowledge signal output for system control
33	HDIN	I	Serial data input for system control
34	HCLK	I	Clock input for system control
35	HDOUT	O	Serial data output for system control
36	HCS	I	Chip select input for system control
37	SDCLK	O	Not used (open)
38	CLKEN	O	Not used (open)
39	RAS	O	Not used (open)
40	VDDI	I	Power supply
41	VSS	—	Ground
42	CAS	O	Not used (open)
43	DQM/OE0	O	Not used (open)
44	CS0	O	External memory chip select (SRAM)
45	WE0	O	SRAM write enable output
46	VDDE	I	Power supply
47	WMD1	I	Not used (connected to "H")
48	VSS	—	Ground
49	WIMD0	I	Not used (connected to ground)
50	PAGE2	O	Not used (open)
51	VSS	—	Ground
52	PAGE1	O	External memory page switching signal output (Not used)
53	PAGE0	O	External memory page switching signal output (Not used)

Pin No.	Pin Name	I/O	Description
54	BOOT	I	Not used (connected to ground)
55	BTACT	O	Not used (open)
56	BST	I	Boot stop signal input
57	MOD1	I	Operation mode signal input (L : 386fs, H : 256fs)
58	MOD0	I	Operation mode signal input (L : single chip mode, H : use prohibited)
59	EXLOCK	I	Lock signal input
60	VDDI	I	Power supply
61	VSS	—	Ground
62, 63	A17, A16	O	Not used (open)
64 to 66	A15 to A13	O	External memory address output (SRAM)
67	GP10	O	LRCK0
68	GP9 (DECODE)	O	DECODE
69	GP8 (AUDIO)	I	AUDIO
70	VDDI	I	Power supply
71	VSS	—	Ground
72 to 75	D15/GP7 to D12/GP4	I/O	External memory data input/output (general port)
76	VDDE	I	Power supply
77 to 80	D11/GP3 to D8/GP0	I/O	External memory data input/output (general port)
81	VSS	—	Ground
82 to 85	A9 to A12	O	External memory address output (SRAM)
86	TDO	O	Not used (open)
87	TMS	I	Not used (open)
88	XTRST	I	Not used (open)
89	TCK	I	Not used (open)
90	TDI	I	Not used (open)
91	VSS	—	Ground
92 to 97	A8 to A3	O	External memory address output (SRAM)
98, 99	D7, D6	I/O	External memory data input/output (SRAM)
100	VDDI	I	Power supply
101	VSS	—	Ground
102 to 105	D5 to D2	I/O	External memory data input/output (SRAM)
106	VDDE	I	Power supply
107, 108	D1, D0	I/O	External memory data input/output (SRAM)
109, 110	A2, A1	O	External memory address output (SRAM)
111	VSS	—	Ground
112	A0	O	External memory address output (SRAM)
113	PM	I	PLL initialization input terminal
114, 115	SDI3, SDI4	I	Not used (open)
116	SYNC	I	Sync/async selection input (L : sync, H : async)
117 to 119	VSS	—	Ground
120	VDDI	I	Power supply

## • IC1601 MB90478PF-G-120-BND (SYSTEM CONTROL) (DIGITAL Board (2/2))

Pin No.	Pin Name	I/O	Description
1	DATAO	I	Serial data input for DIR
2	GP9	I	Decode signal input
3	BST	O	Boot stop signal output to DSP
4	HCS	O	Chip select signal output to DSP
5	HACN	I	Acknowledge signal input for DSP
6	XRST	O	Reset signal output to DSP
7	PM	O	PLL initialization output to DSP
8	PD	O	Power down signal output to CODEC
9	SMUTE	O	Soft mute signal output to CODEC
10	CDT1	O	Control data output to CODEC
11	VSS	—	Ground
12	SCL	O	Serial data clock to CODEC
13	CS	O	Chip select signal output to CODEC
14	DATA	O	Serial data output to VOL/TUNER
15	CLK	O	Clock signal output to VOL/TUNER
16	LATCH	O	Latch signal output to VOL/TUNER
17	SPKB	O	Speaker out control signal output (Not used)
18	HDOUT	I	Serial data for DSP
19	HDIN	O	Serial data to DSP
20	HCLK	O	Clock signal output to DSP
21	F.MUTE	O	Function input mute signal output
22	AC MUTE	O	Power amp mute signal output
23	VCC5	I	Power supply
24	ANA/DIG	I	Muting and error port signal input
25	HP DETECT	I	Headphone detect signal input
26	DCS LED	O	LED (DCS) driver signal output
27	FLASH2	O	Flash programming signal output
28	SP SWITCH/FLASH1	I/O	Speaker ON/OFF signal output
29	BLUE LED	O	LED (MULTI CHANNEL) driver signal output
30	MODE	O	LED (MODE) driver signal output
31	2CH	O	LED (2CH) driver signal output
32	AFD	O	LED (AFD) driver signal output
33	SCL	O	Clock signal output to EEPROM
34	SDA	I/O	Serial data to EEPROM
35	AVCC	I	Power supply
36	AVRH	I	Not used (connected to "H")
37	AVSS	—	Ground
38 to 41	A/D0 to A/D3	I	Key signal input (A/D port)
42	VSS	—	Ground
43	RDS SIGNAL	I	RDS signal input
44	MODEL	I	Model detection port
45	VERSION	I	Version resistor port
46	NC	O	Not used (connected to ground)
47	NC	O	Not used (connected to ground)
48	STOP	I	Input signal when AC off
49	MD0	—	Selection of micom operation mode
50	MD1	—	Not used (connected to ground)
51	MD2	—	Selection of micom operation mode
52	RDS CLOCK	I	RDS clock signal output (Not used)
53	RDS DATA	I	RDS data output (Not used)
54	SIRCS	I	Input data from remote control receiver
55	FUSE DETECT	I	Power down detect input

Pin No.	Pin Name	I/O	Description
56	POWER KEY	I	Detect power switch key
57	JOG (B)	I	Jog encoder signal input (Not used)
58	JOG (A)	I	Jog encoder signal input (Not used)
59	VOL (B)	I	Volume encoder signal input
60	VOL (A)	I	Volume encoder signal input
61	DIN	O	Serial data output to FL driver
62	CLK	O	Clock signal output to FL driver
63	FL_STB	O	Strobe signal output to FL driver
64	CONTROL A1 OUT	O	Control A1 signal output
65	CONTROL A1 IN	I	Control A1 signal input
66	POWER RELAY	O	Control power relay driver output
67	PROTECTOR	I	Detect protector status input
68	HEADPHONE RELAY	O	Control headphone relay driver output
69	WOOFER RELAY	O	Control woofer speaker relay driver output
70	REAR RELAY	O	Control rear speaker relay driver output
71	CENTER RELAY	O	Control center speaker relay driver output
72	PREOUT/FRONT RELAY	O	Control front speaker relay driver output
73	TUNED	O	Tuned signal output to tuner
74	STEREO	O	Stereo signal output to tuner
75	MUTE	O	Mute signal output to tuner
76	DO	I	Serial data input for tuner
77	RSTX	I	Reset signal input
78	SLATCH	O	Latch signal to tuner
79	X1A	—	Not used (open)
80	X0A	—	Not used (connected to ground)
81	VSS	—	Ground
82	X0	I	Clock signal input (20 MHz)
83	X1	O	Clock signal output (20 MHz)
84	VCC3	I	Power supply
85	NC	I	Not used
86	NC	O	Not used
87 to 90	SW4 to SW1	O	Video input select signal output
91	SELECT1	O	Optical input select signal output (Not used)
92	SELECT2	O	Optical input select signal output (Not used)
93	XMODE	O	Mode signal output to DIR
94	CKSEL1	O	Clock select signal output to DIR
95	CLK	O	Clock signal output to DIR
96	CE	O	Chip select signal output to DIR
97	DI	O	Serial data output to DIR
98	DO	I	Serial data input for DIR
99	ERROR	I	Error signal input for DIR
100	XSTATE	I	XSTATE signal input for DIR

## 4-2. CIRCUIT BOARDS LOCATION

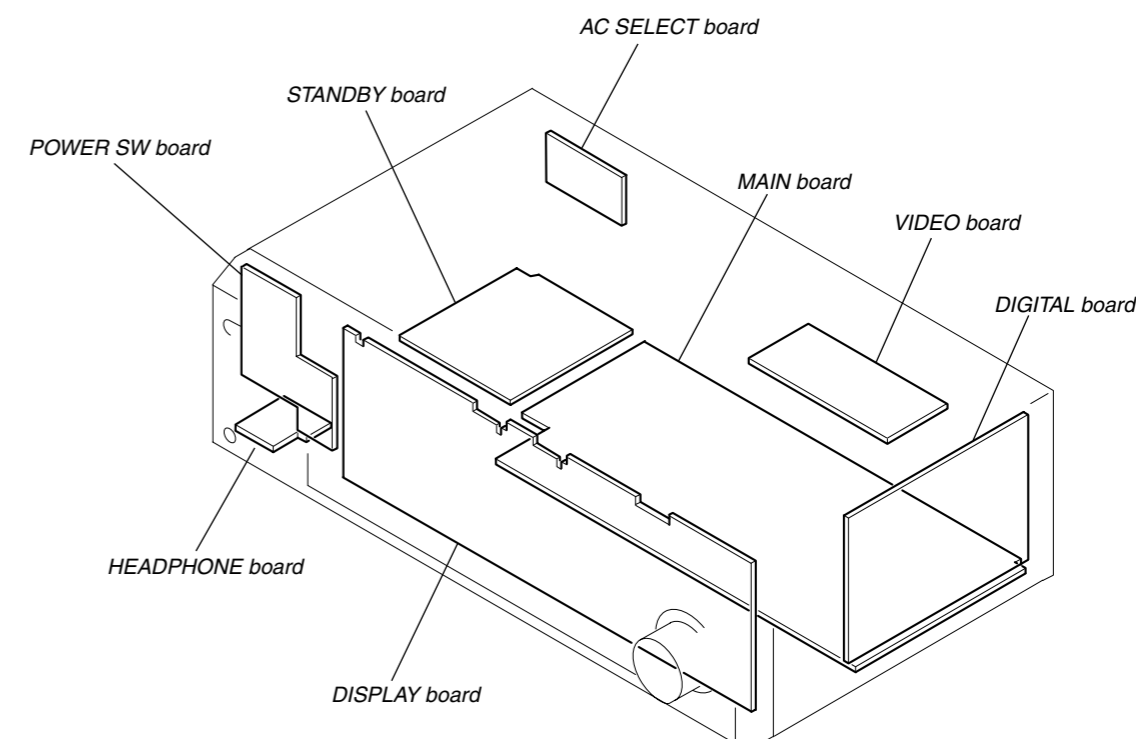

4-3. BLOCK DIAGRAM — TUNER/AUDIO SECTION —

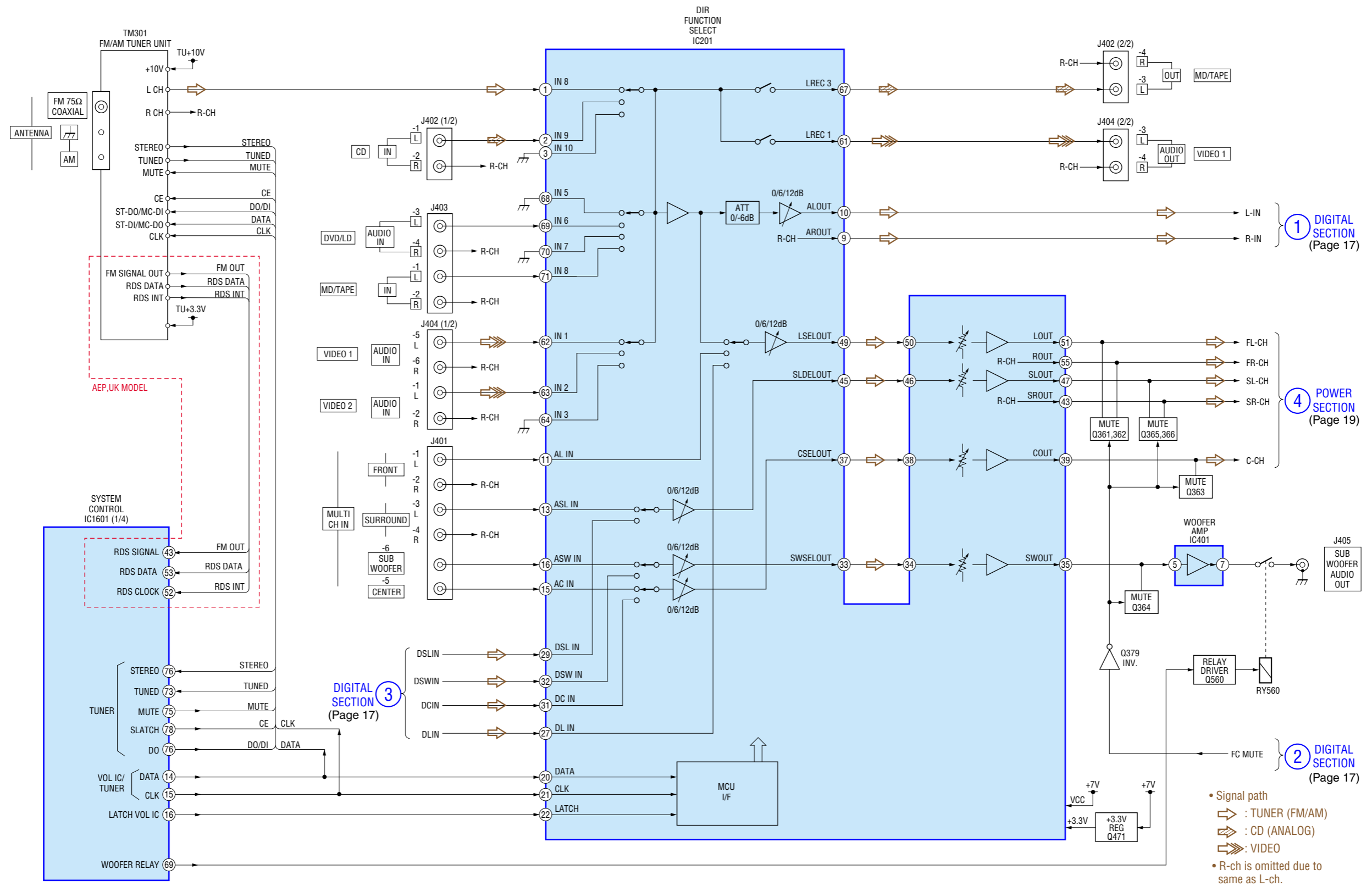



4-4. BLOCK DIAGRAM — DIGITAL SECTION —

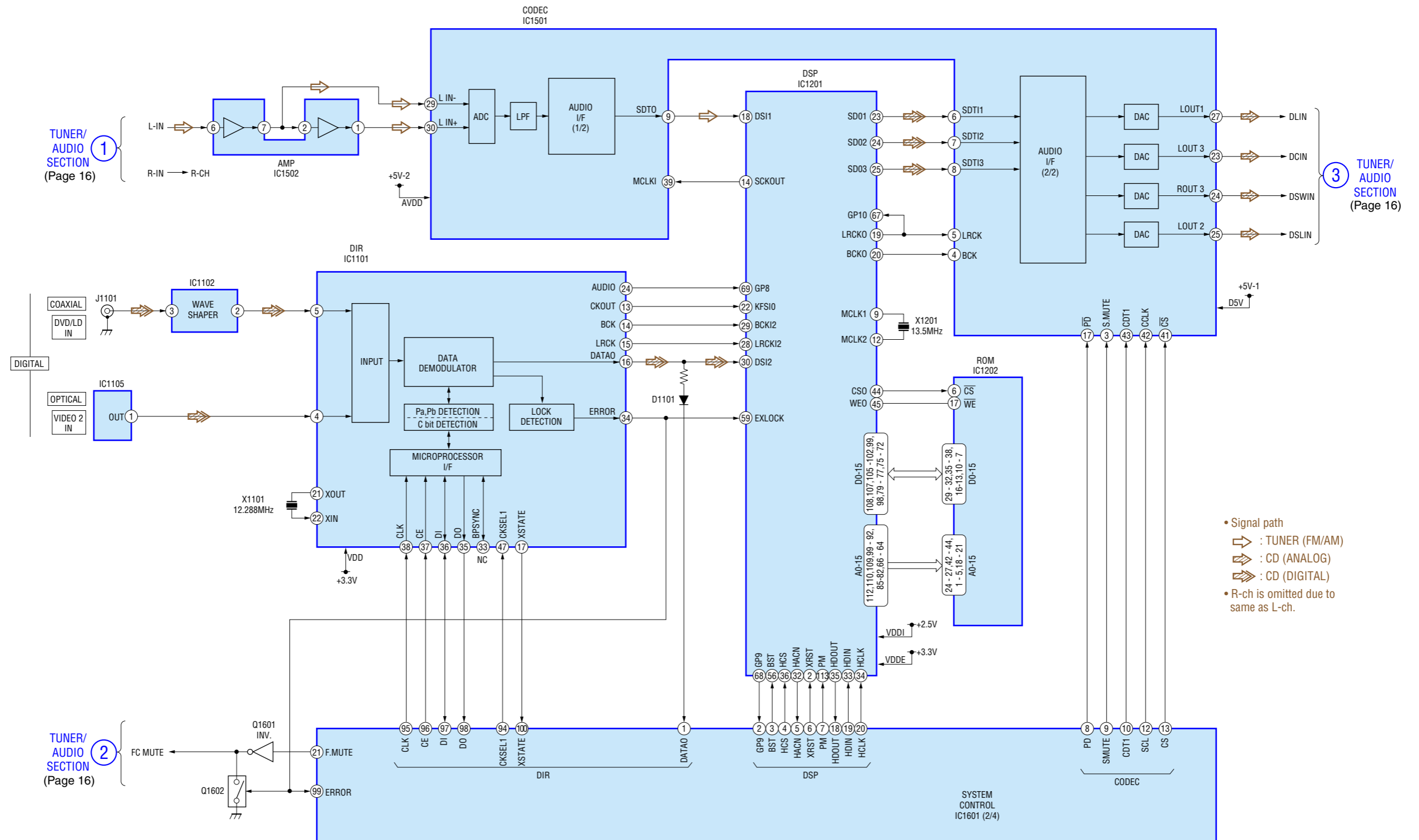

4-5. BLOCK DIAGRAM — VIDEO/DISPLAY SECTION —

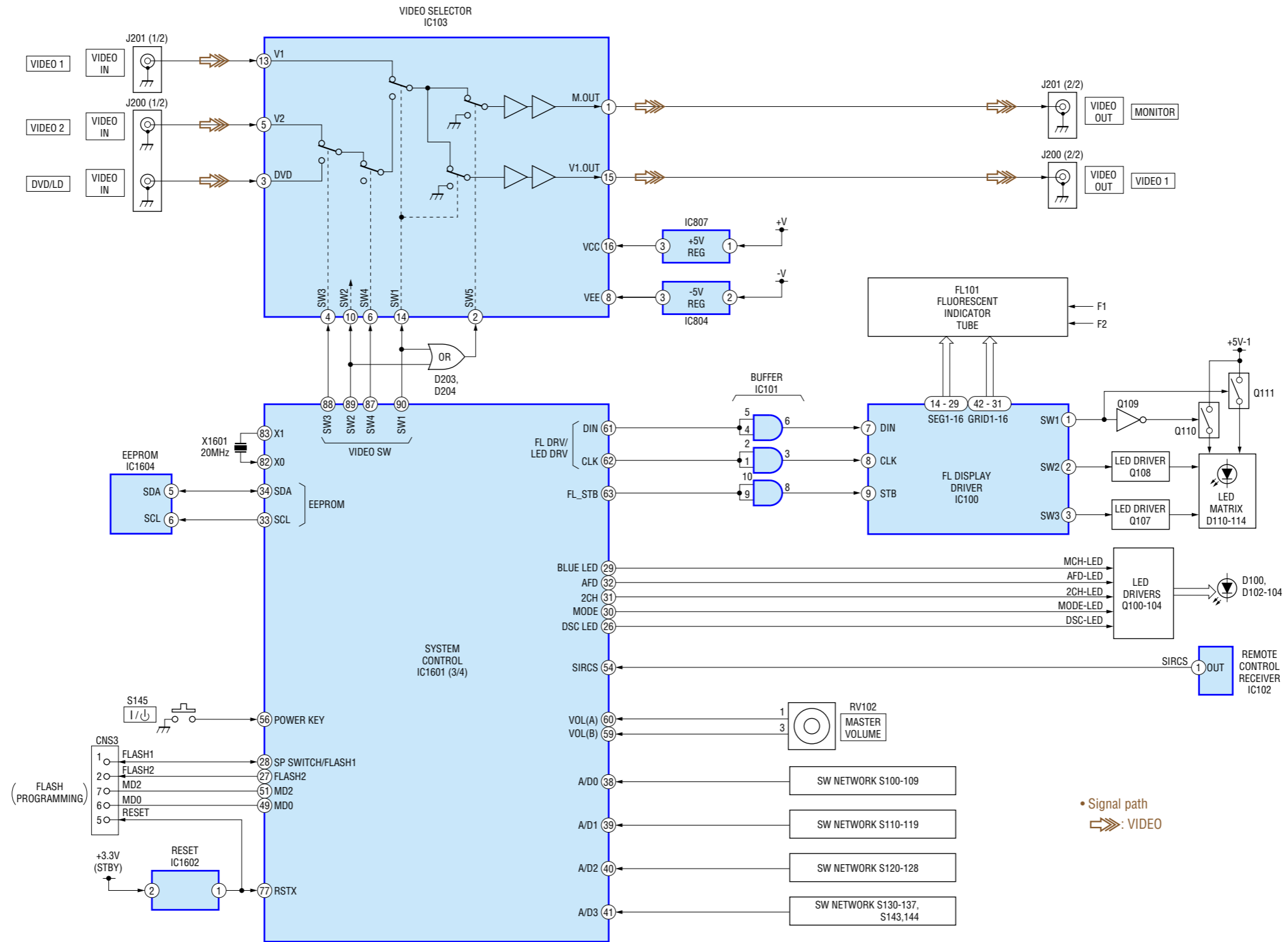

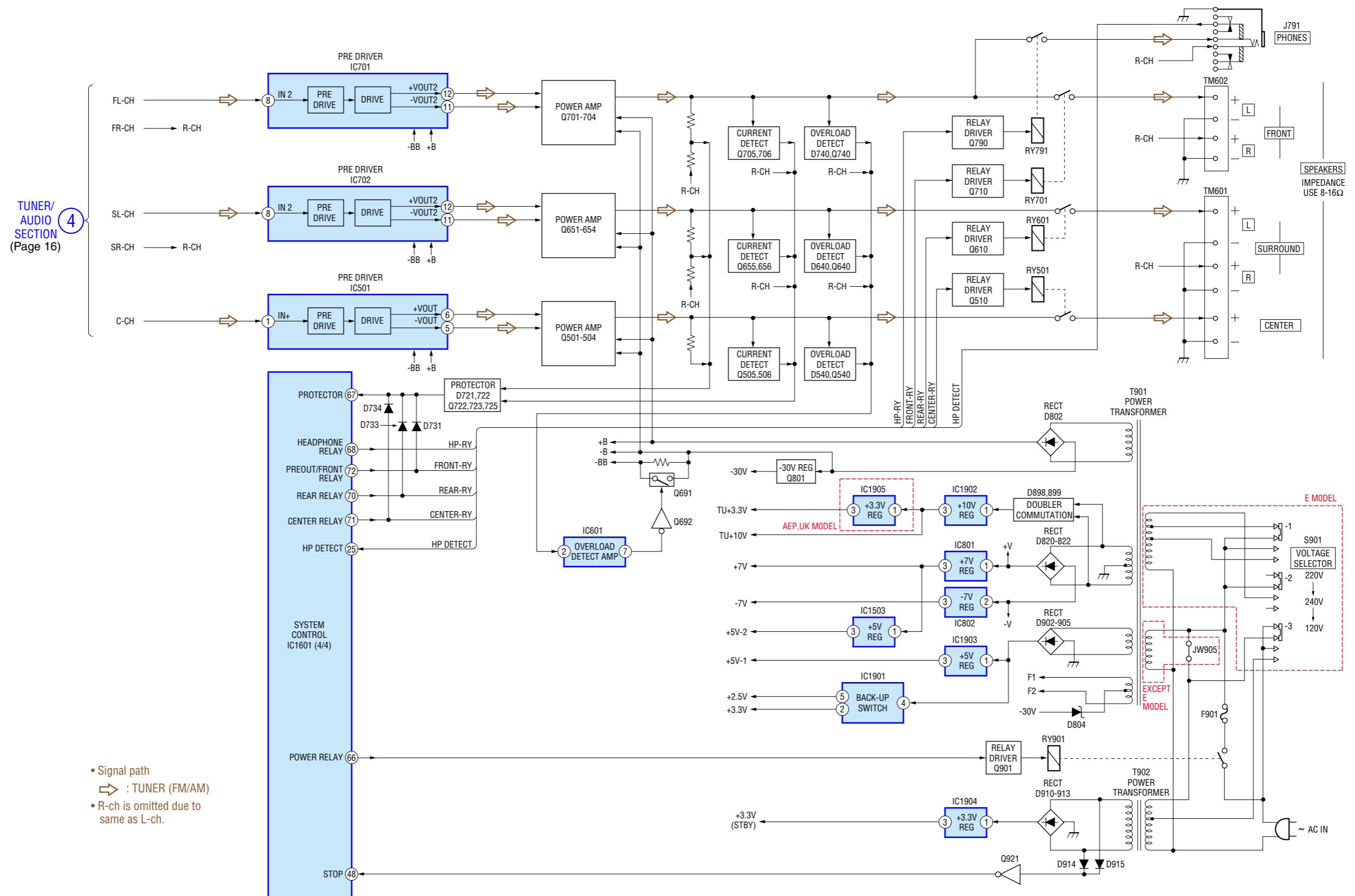

4-6. BLOCK DIAGRAM — POWER SECTION —





**THIS NOTE IS COMMON FOR PRINTED WIRING BOARDS AND SCHEMATIC DIAGRAMS.**  
(In addition to this, the necessary note is printed in each block.)

**for schematic diagram:**

- All capacitors are in  $\mu\text{F}$  unless otherwise noted. pF:  $\mu\mu\text{F}$  50 WV or less are not indicated except for electrolytics and tantalums.
- All resistors are in  $\Omega$  and  $\frac{1}{4} \text{ W}$  or less unless otherwise specified.
- $\Delta$  : internal component.
-  : nonflammable resistor.
-  : fusible resistor.
-  : panel designation.

**for printed wiring boards:**

-  : parts extracted from the component side.
- $\Delta$  : internal component.
-  : Pattern from the side which enables seeing.

**Caution:**



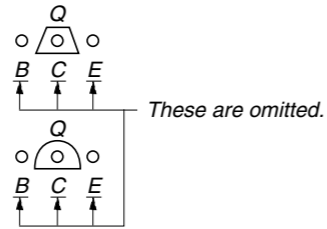
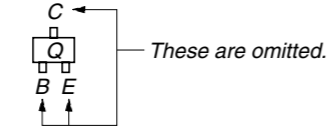



Pattern face side: Parts on the pattern face side seen from the (Side B) pattern face are indicated.  
Parts face side: Parts on the parts face side seen from the (Side A) parts face are indicated.



**Note:**  
The components identified by mark  $\Delta$  or dotted line with mark  $\Delta$  are critical for safety. Replace only with part number specified.

**Note:**  
Les composants identifiés par une marque  $\Delta$  sont critiques pour la sécurité. Ne les remplacer que par une pièce portant le numéro spécifié.

以阴影和  $\Delta$  标志来识别的零部件，在安全方面具有关键性。因此只能以规定号码的零部件来更换。

-  : B+ Line.
-  : B- Line.
- Voltage and waveforms are dc with respect to ground under no-signal (detuned) conditions.  
no mark : FM
- Voltages are taken with a VOM (Input impedance 10 M $\Omega$ ). Voltage variations may be noted due to normal production tolerances.
- Waveforms are taken with a oscilloscope.  
Voltage variations may be noted due to normal production tolerances.
- Circled numbers refer to waveforms.
- Signal path.  
 : TUNER (FM/AM)  
 : VIDEO  
 : CD (ANALOG)  
 : CD (DIGITAL)
- Abbreviation  
CND : Canadian model.  
AR : Argentine model.  
AUS : Australian model.  
CH : Chinese model.  
MX : Mexican model.  
SP : Singapore model.  
TW : Taiwan model.

**• Waveform (DIGITAL Board)**

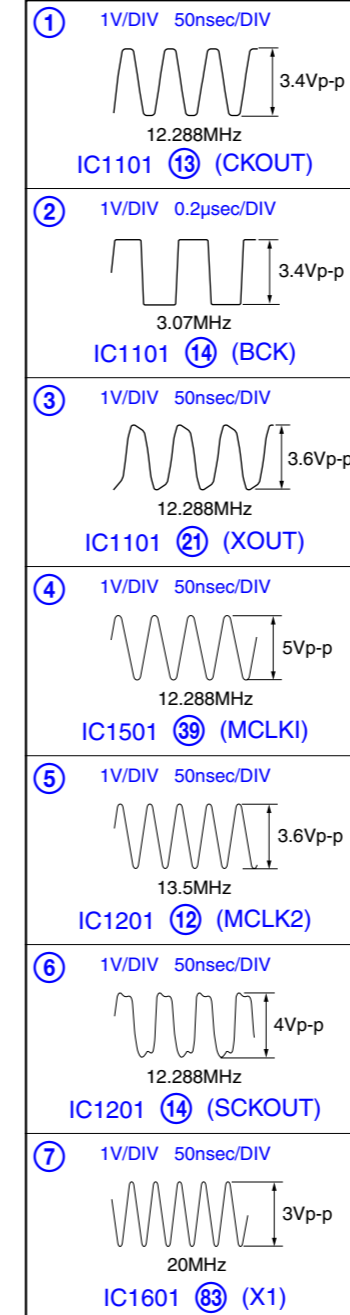

4-7. PRINTED WIRING BOARDS — MAIN SECTION — • Refer to page 15 for Circuit Boards Location and page 20 for Common Note on Printed Wiring Boards.

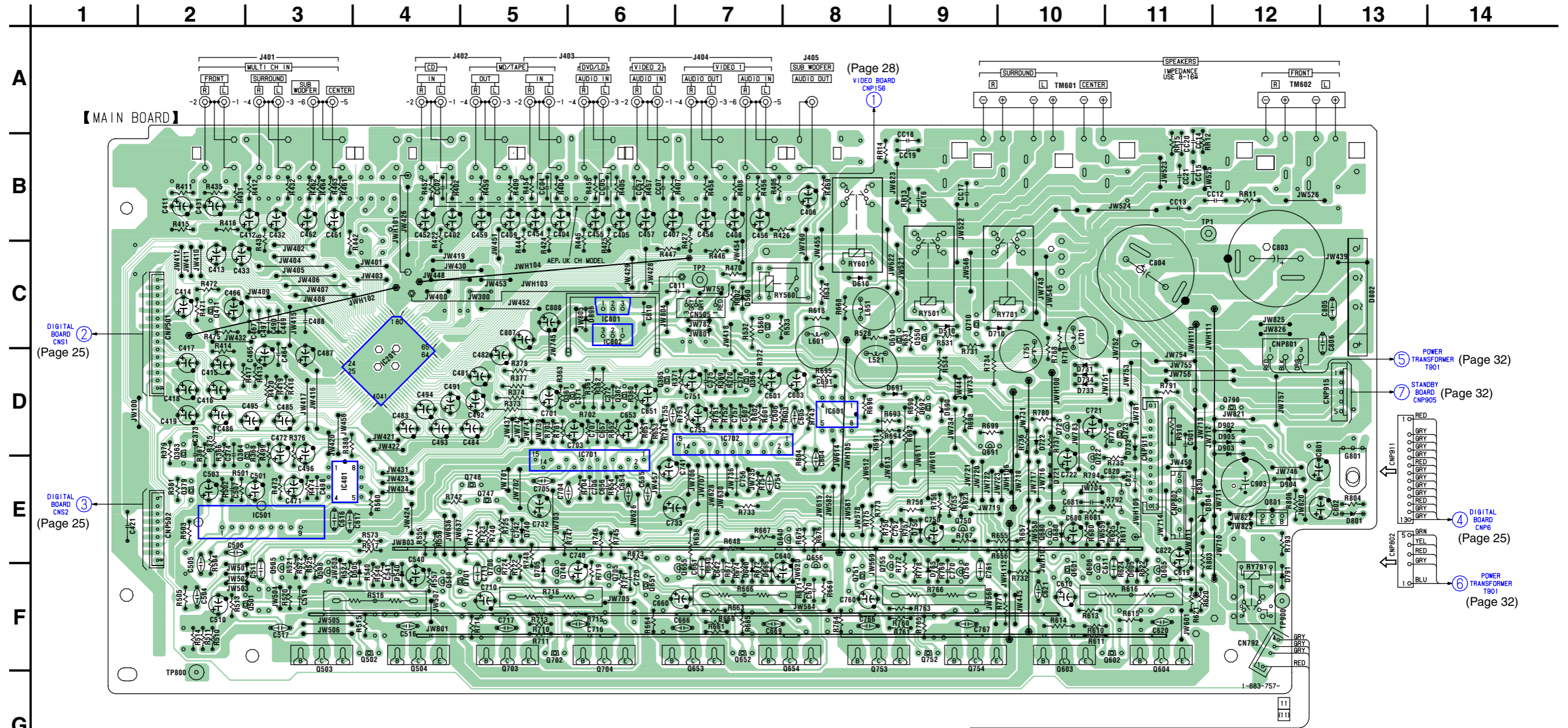

• Semiconductor Location

Ref. No.	Location	Ref. No.	Location	Ref. No.	Location	Ref. No.	Location	Ref. No.	Location
D505	F-4	D750	E-9	Q361	D-5	Q604	F-11	Q710	C-9
D510	C-9	D765	F-9	Q362	D-6	Q605	F-11	Q722	E-10
D540	F-4	D791	F-12	Q363	D-2	Q606	F-10	Q723	D-11
D560	C-7	D801	E-13	Q364	D-2	Q610	C-9	Q725	D-10
D605	F-11	D802	C-13	Q365	D-6	Q640	E-8	Q740	F-5
D610	C-8	D804	E-11	Q366	D-7	Q651	F-6	Q747	E-5
D640	F-7	D896	C-6	Q379	E-2	Q652	F-7	Q748	E-5
D665	F-7	D902	D-12	Q471	C-2	Q653	F-7	Q750	E-9
D680	E-10	D903	D-12	Q501	F-3	Q654	F-8	Q751	F-8
D690	D-9	D904	E-12	Q502	F-4	Q655	F-7	Q752	F-9
D691	D-9	D905	D-12	Q503	F-3	Q656	E-8	Q753	F-8
D705	F-5			Q504	F-4	Q680	E-10	Q754	F-9
D710	C-9			Q505	F-3	Q691	D-9	Q755	F-8
D721	E-10	IC201	D-4	Q506	F-3	Q692	D-9	Q756	F-9
D722	D-10	IC401	E-3	Q507	F-3	Q693	D-9	Q757	F-9
D731	D-10	IC501	E-3	Q540	F-4	Q701	F-4	Q790	D-12
D732	D-11	IC601	D-8	Q550	C-9	Q702	F-5	Q801	E-12
D733	D-10	IC701	E-6	Q560	C-7	Q703	F-5		
D734	D-10	IC702	D-7	Q601	F-10	Q704	F-6		
D740	E-5	IC801	C-6	Q602	F-11	Q705	F-6		
		IC802	C-6	Q603	F-10	Q706	F-5		

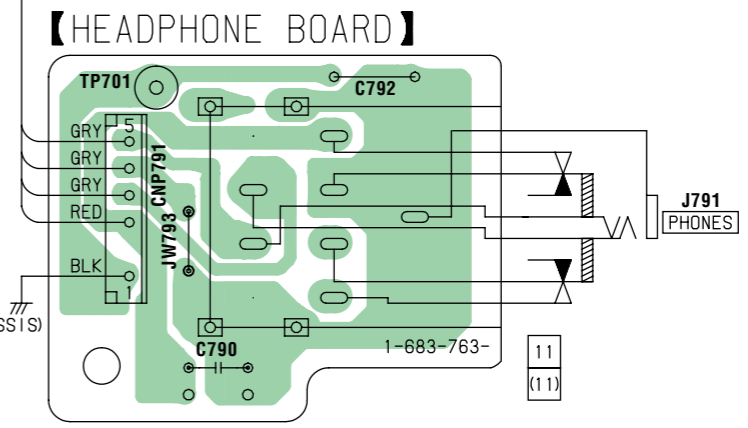

4-8. SCHEMATIC DIAGRAM — MAIN SECTION (1/2) — • Refer to page 20 for Common Note on Schematic Diagram.

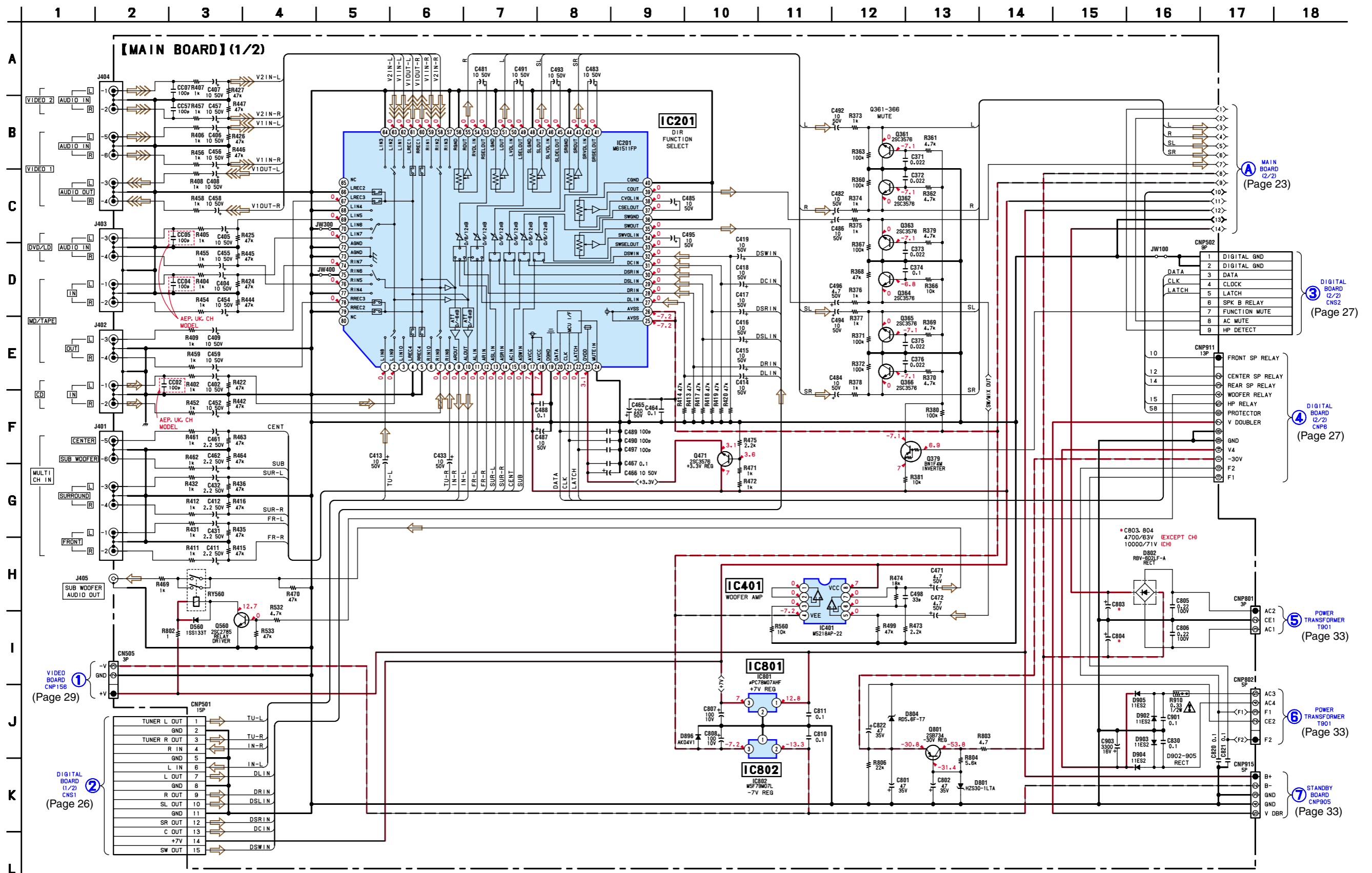

The components identified by mark △ or dotted line with mark △ are critical for safety. Replace only with part number specified.

Les composants identifiés par une marque △ sont critiques pour la sécurité. Ne les remplacer que par une pièce portant le numéro spécifié.

以阴影和△标志来识别的零部件，在安全方面具有关键性。因此只能以规定号码的零部件来更换。

4-9. SCHEMATIC DIAGRAM — MAIN SECTION (2/2) — • Refer to page 20 for Common Note on Schematic Diagram and page 34 for IC Block Diagrams.

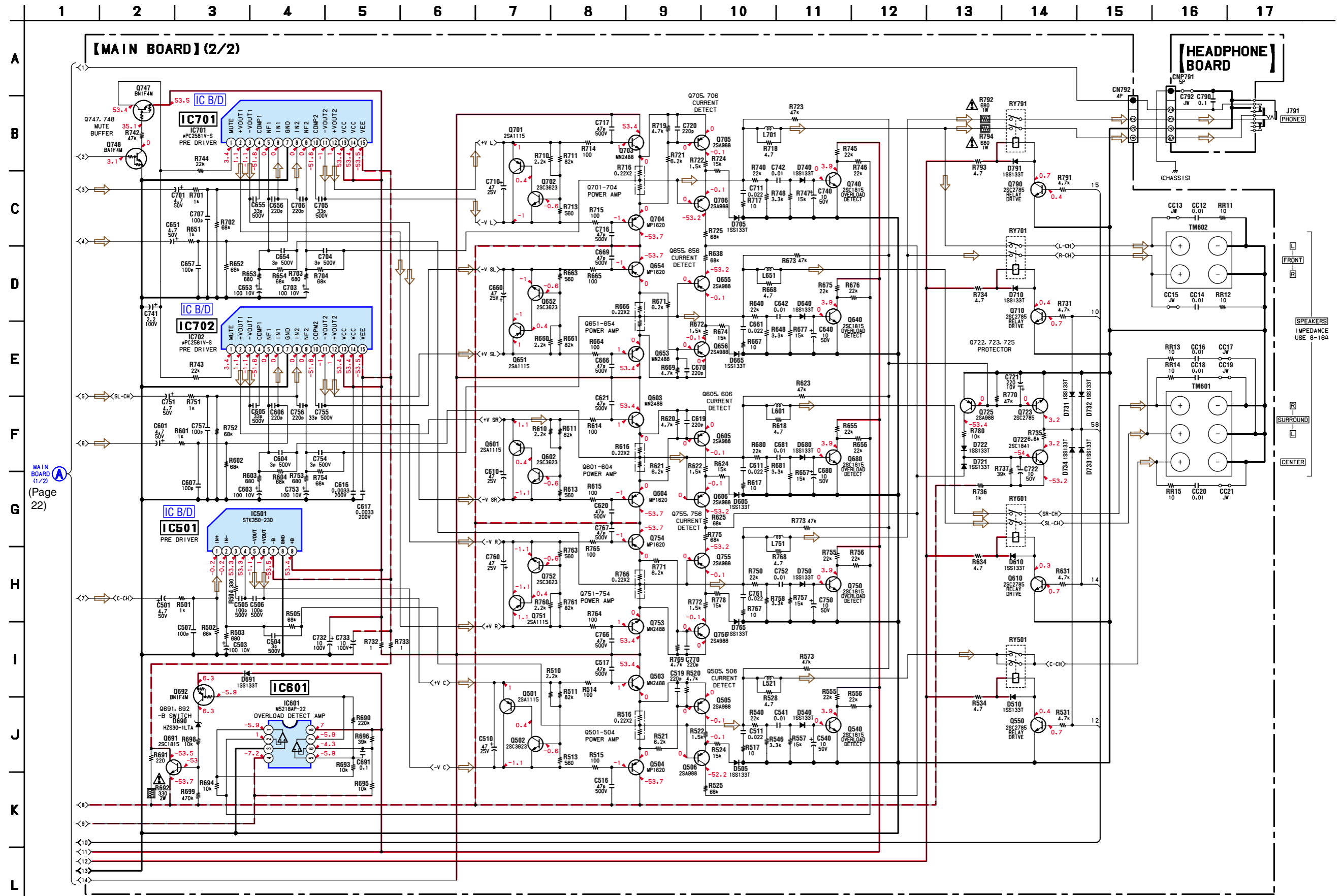

MAIN BOARD (1/2) (Page 22)

The components identified by mark  $\triangle$  or dotted line with mark  $\triangle$  are critical for safety. Replace only with part number specified.

Les composants identifiés par une marque  $\triangle$  sont critiques pour la sécurité. Ne les remplacer que par une pièce portant le numéro spécifié.

以阴影和  $\triangle$  标志来识别的零部件，在安全方面具有关键性。因此只能以规定号码的零部件来更换。

4-10. PRINTED WIRING BOARD — DIGITAL SECTION (1/2) — • Refer to page 15 for Circuit Boards Location and page 20 for Common Note on Printed Wiring Boards.

13 | 12 | 11 | 10 | 9 | 8 | 7 | 6 | 5 | 4 | 3 | 2 | 1

A  
B  
C  
D  
E  
F  
G  
H  
I  
J

• Semiconductor Location

Ref. No.	Location
D1001	G-10
D1101	F-10
D1601	H-5
IC1101	E-10
IC1102	H-11
IC1201	F-7
IC1202	D-7
IC1501	G-9
IC1502	H-9
IC1552	H-8
IC1601	H-5
IC1602	H-3
IC1604	H-3
Q1601	I-5
Q1602	I-5

【DIGITAL BOARD】(SIDE A)

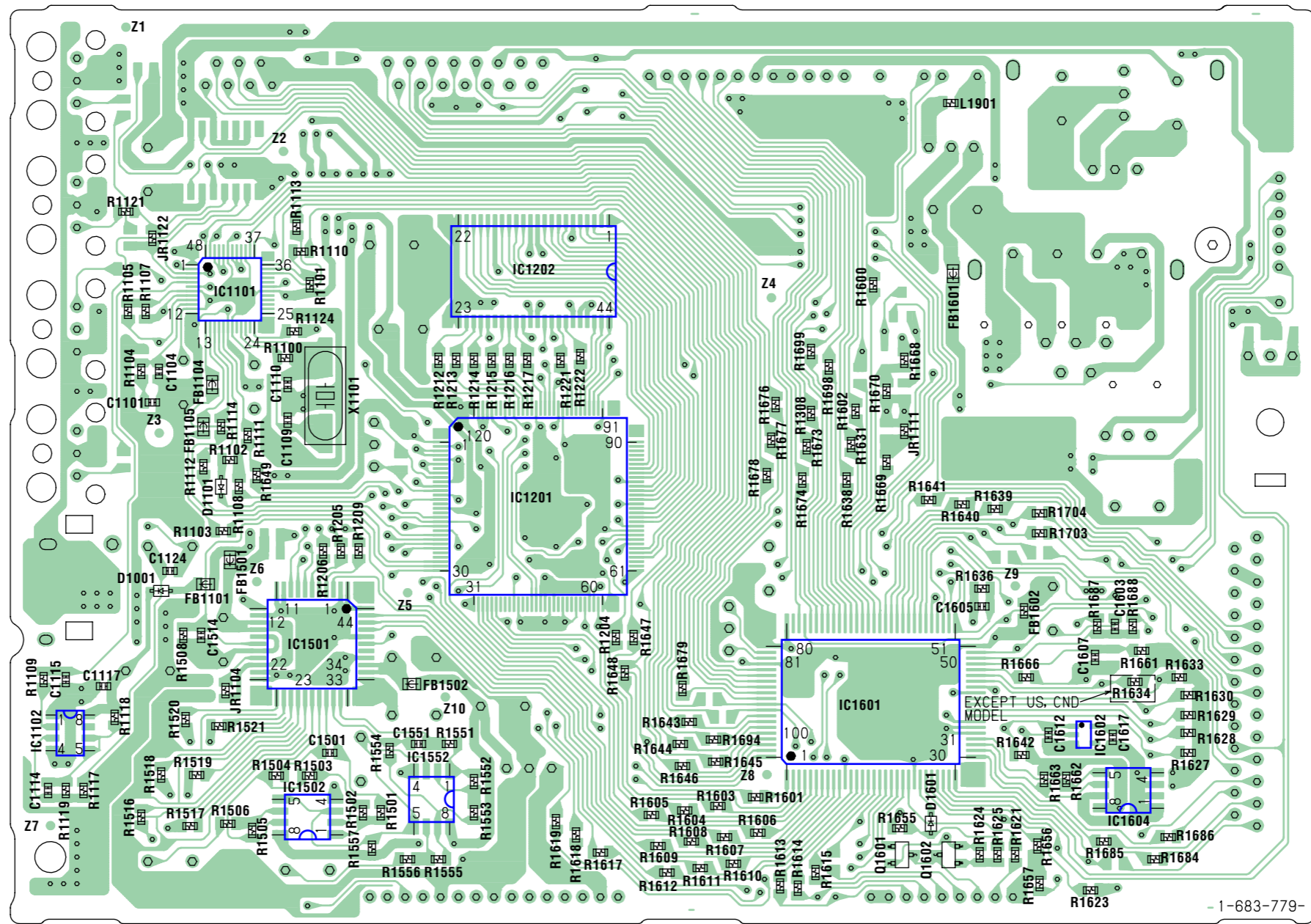

-1-683-779-

11  
(11)



4-11. PRINTED WIRING BOARD — DIGITAL SECTION (2/2) — • Refer to page 15 for Circuit Boards Location and page 20 for Common Note on Printed Wiring Boards.

1 2 3 4 5 6 7 8 9 10 11 12 13

A  
B  
C  
D  
E  
F  
G  
H  
I  
J

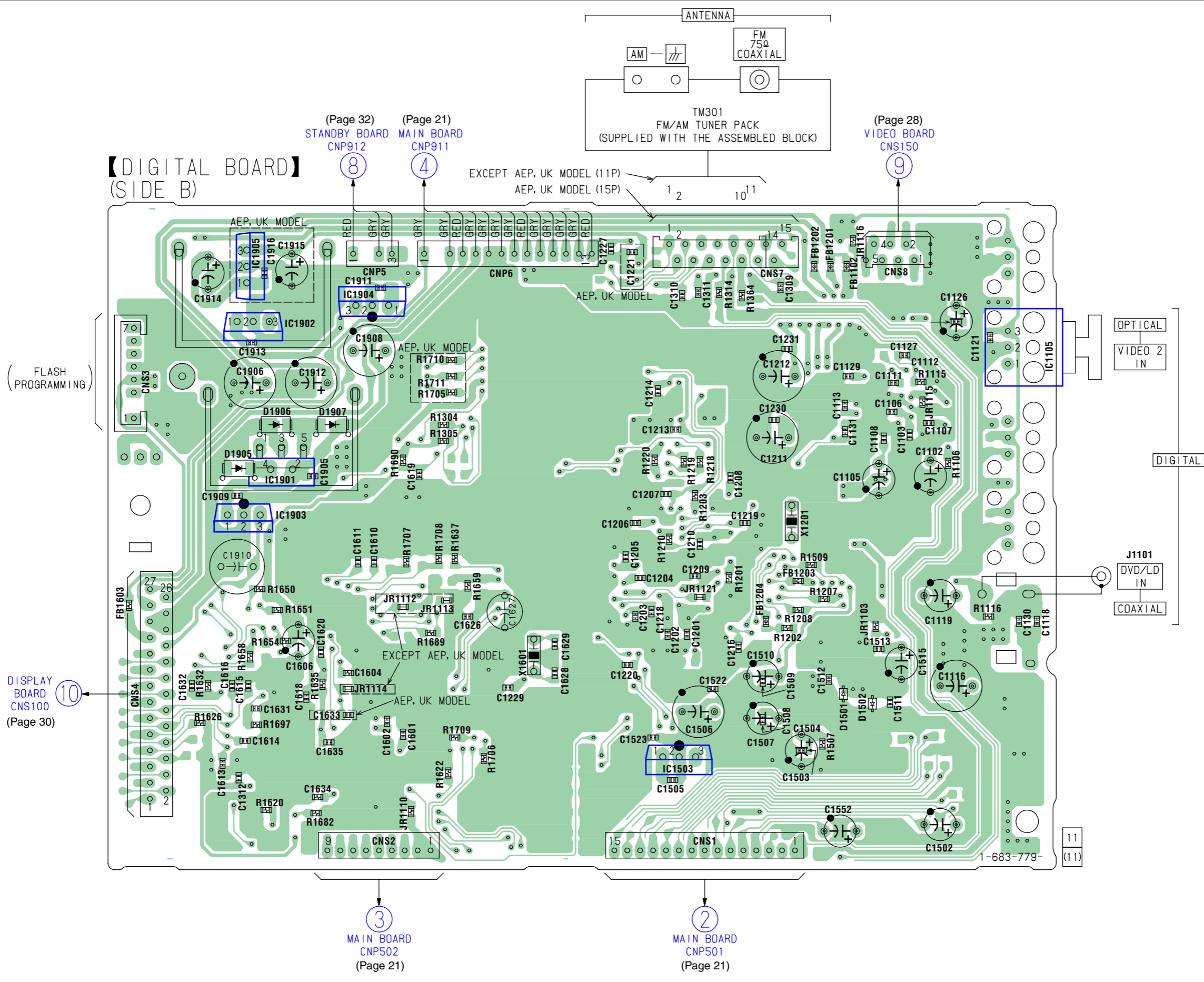

• Semiconductor Location

Ref. No.	Location
D1501	H-9
D1502	H-9
D1905	E-3
D1906	E-3
D1907	E-4
IC1105	D-11
IC1503	H-8
IC1901	E-3
IC1902	D-3
IC1903	F-3
IC1904	C-4
IC1905	C-3

4-12. SCHEMATIC DIAGRAM — DIGITAL SECTION (1/2) — • Refer to page 20 for Common Note on Schematic Diagram and Waveform and page 34 for IC Block Diagrams.

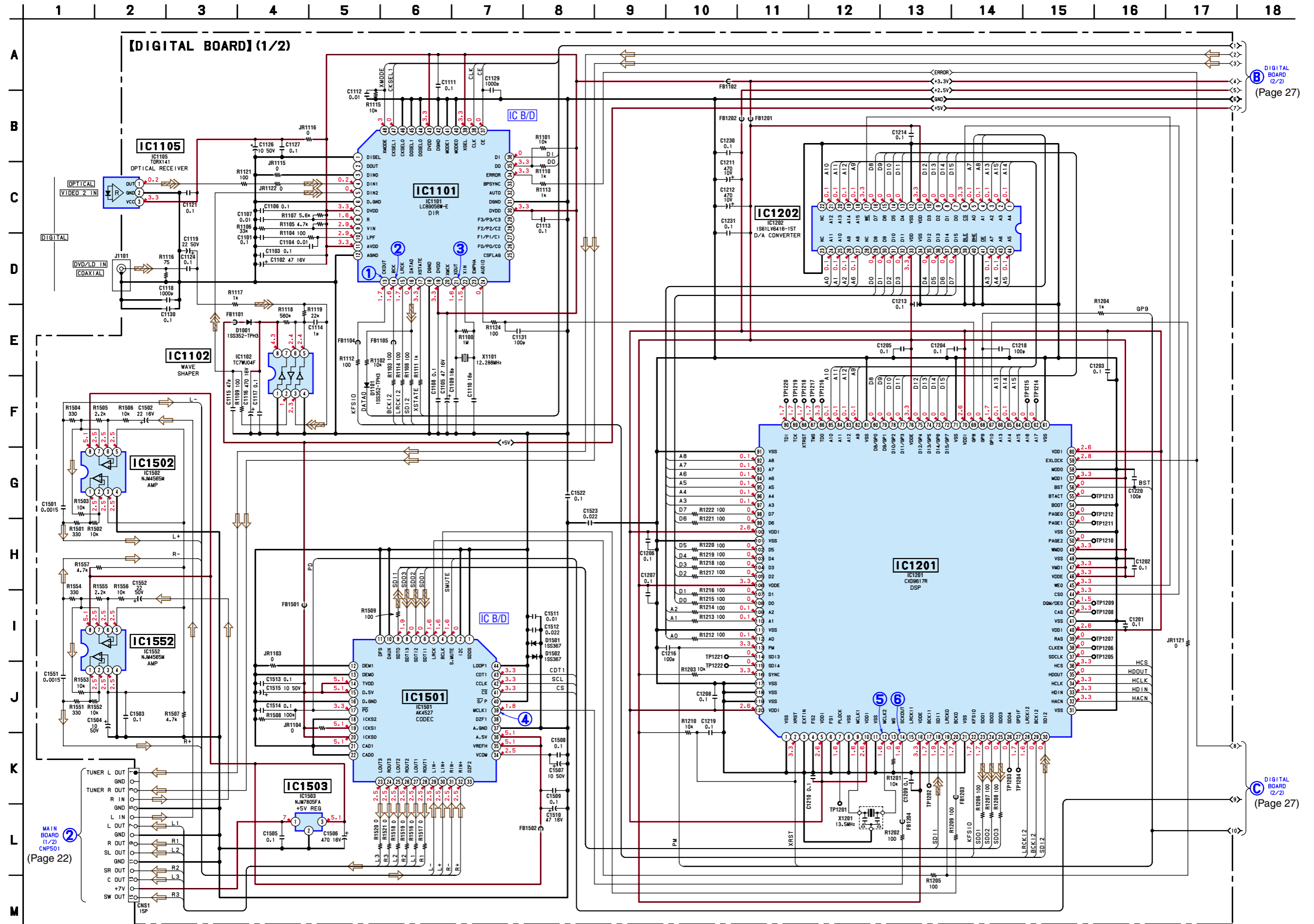

DIGITAL BOARD (2/2) (Page 27)

DIGITAL BOARD (2/2) (Page 27)

4-13. SCHEMATIC DIAGRAM — DIGITAL SECTION (2/2) — • Refer to page 20 for Common Note on Schematic Diagram and Waveform.

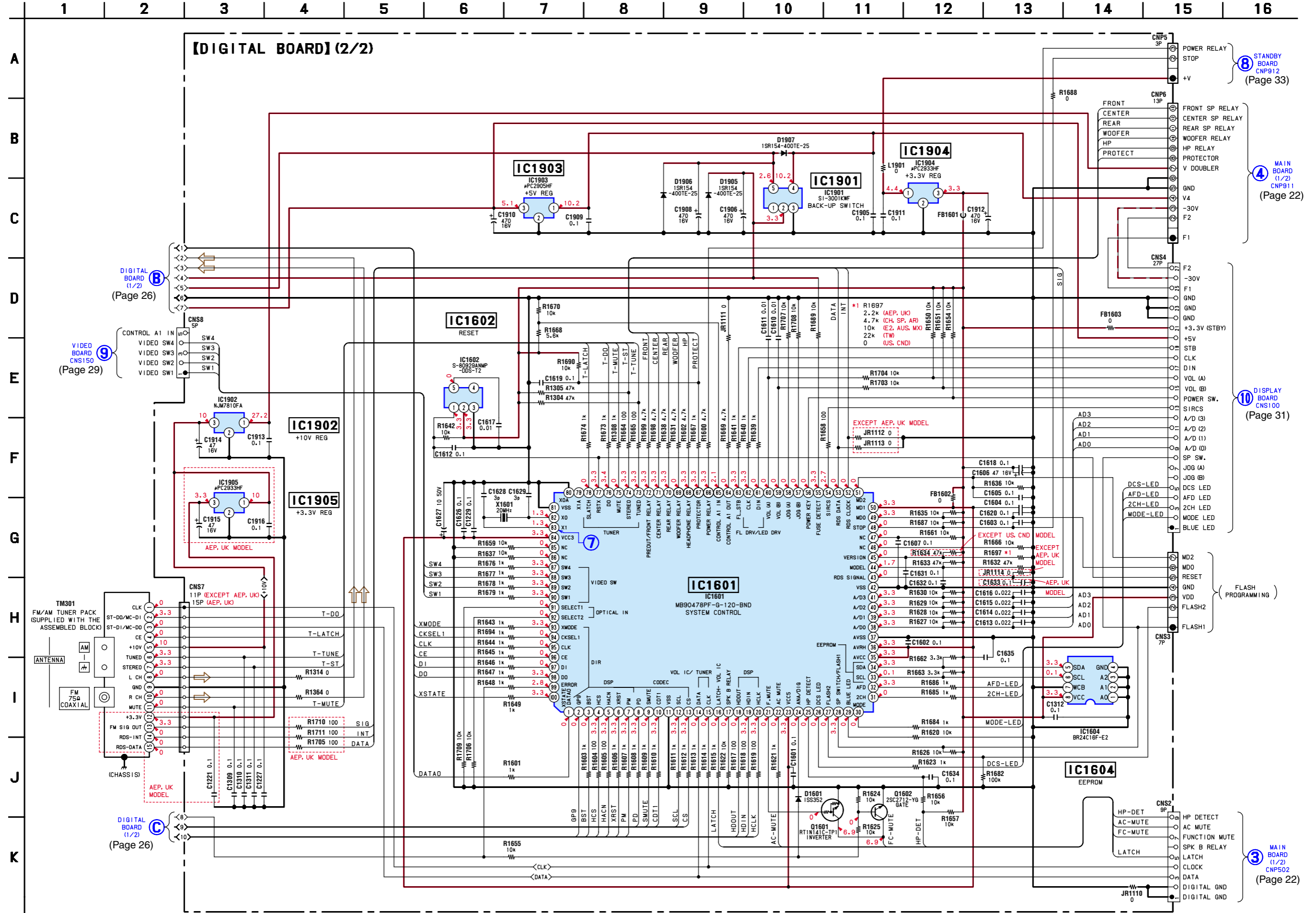

4-14. PRINTED WIRING BOARD — VIDEO SECTION — • Refer to page 15 for Circuit Boards Location and page 20 for Common Note on Printed Wiring Boards.

• Semiconductor Location

Ref. No.	Location
D203	F-4
D204	F-4
IC103	E-7
IC804	E-10
IC807	C-11

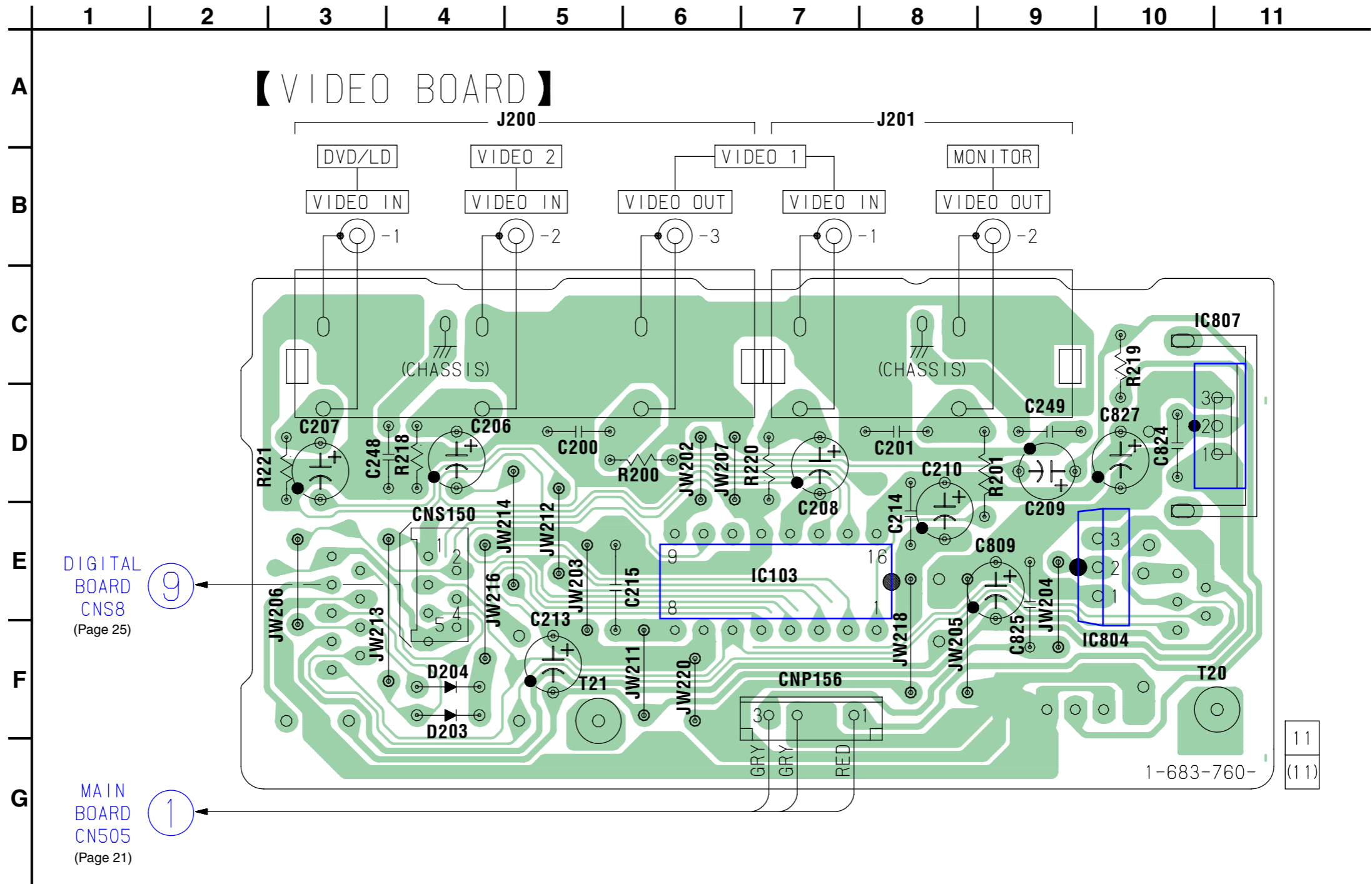

4-15. SCHEMATIC DIAGRAM — VIDEO SECTION — • Refer to page 20 for Common Note on Schematic Diagram and page 34 for IC Block Diagrams.

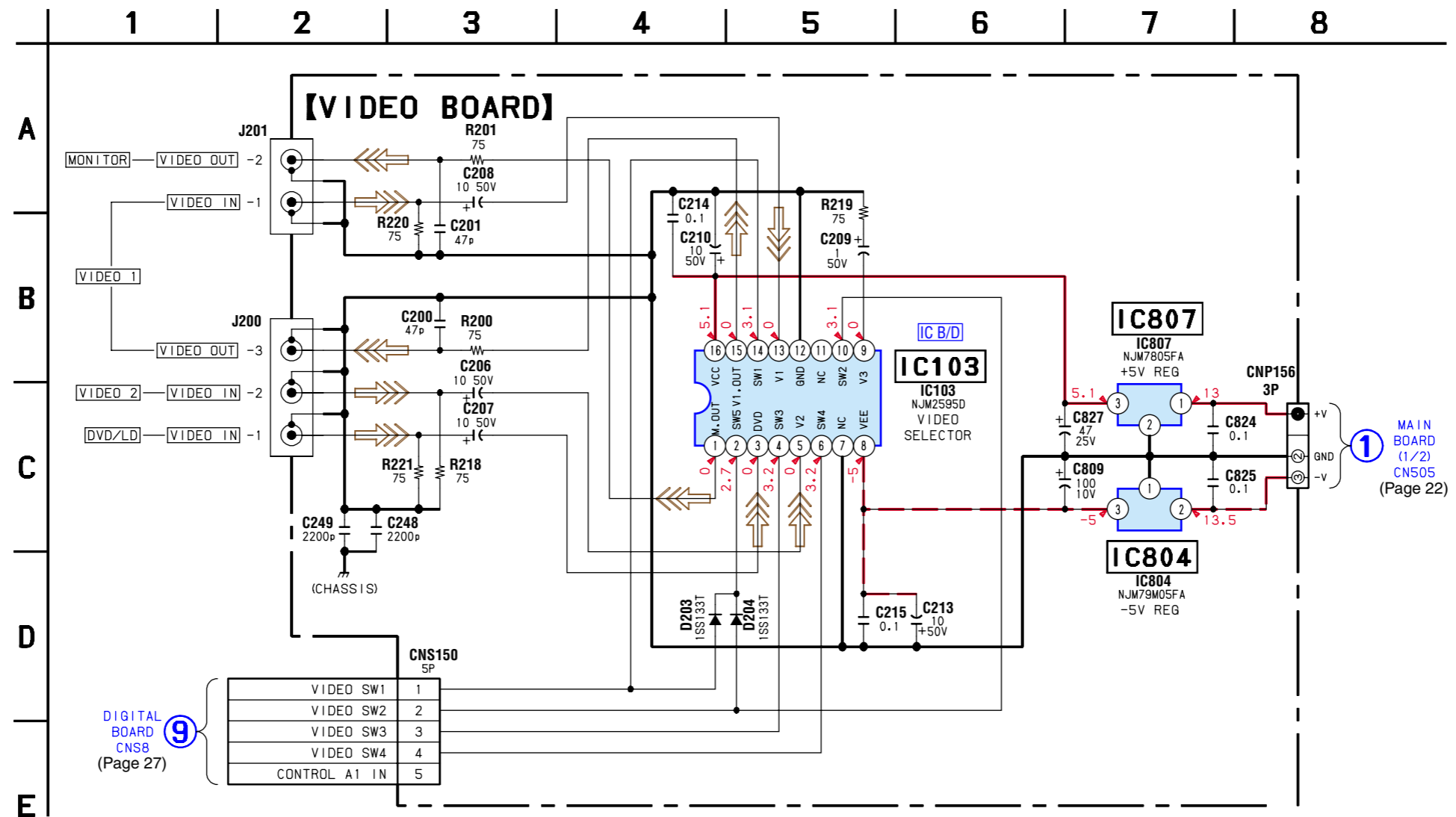

4-16. PRINTED WIRING BOARDS — DISPLAY SECTION — • Refer to page 15 for Circuit Boards Location and page 20 for Common Note on Printed Wiring Boards.

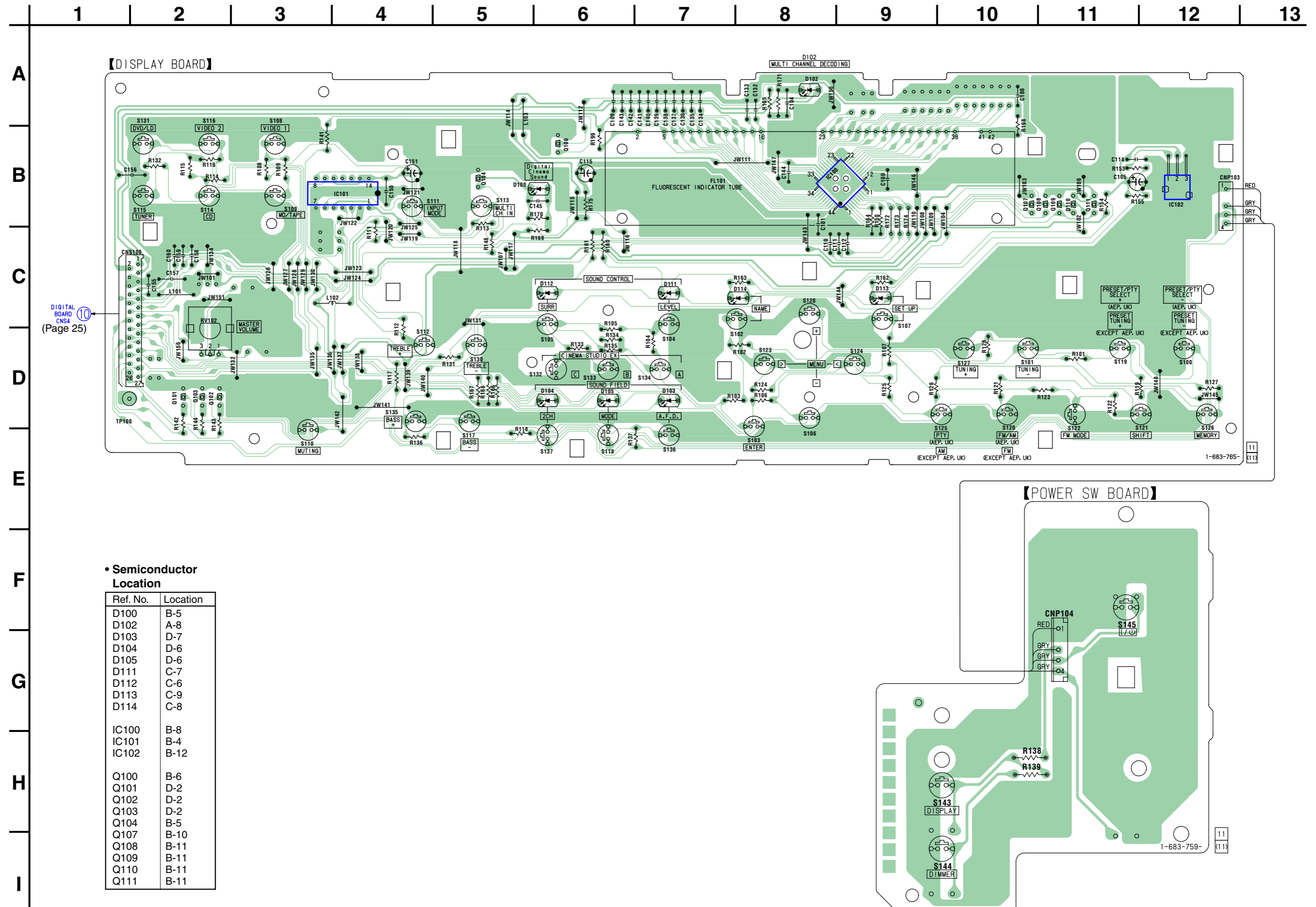

• Semiconductor Location

Ref. No.	Location
D100	B-5
D102	A-8
D103	D-7
D104	D-6
D105	D-6
D111	C-7
D112	C-6
D113	C-9
D114	C-8
IC100	B-8
IC101	B-4
IC102	B-12
Q100	B-6
Q101	D-2
Q102	D-2
Q103	D-2
Q104	B-5
Q107	B-10
Q108	B-11
Q109	B-11
Q110	B-11
Q111	B-11

4-17. SCHEMATIC DIAGRAM — DISPLAY SECTION — • Refer to page 20 for Common Note on Schematic Diagram.

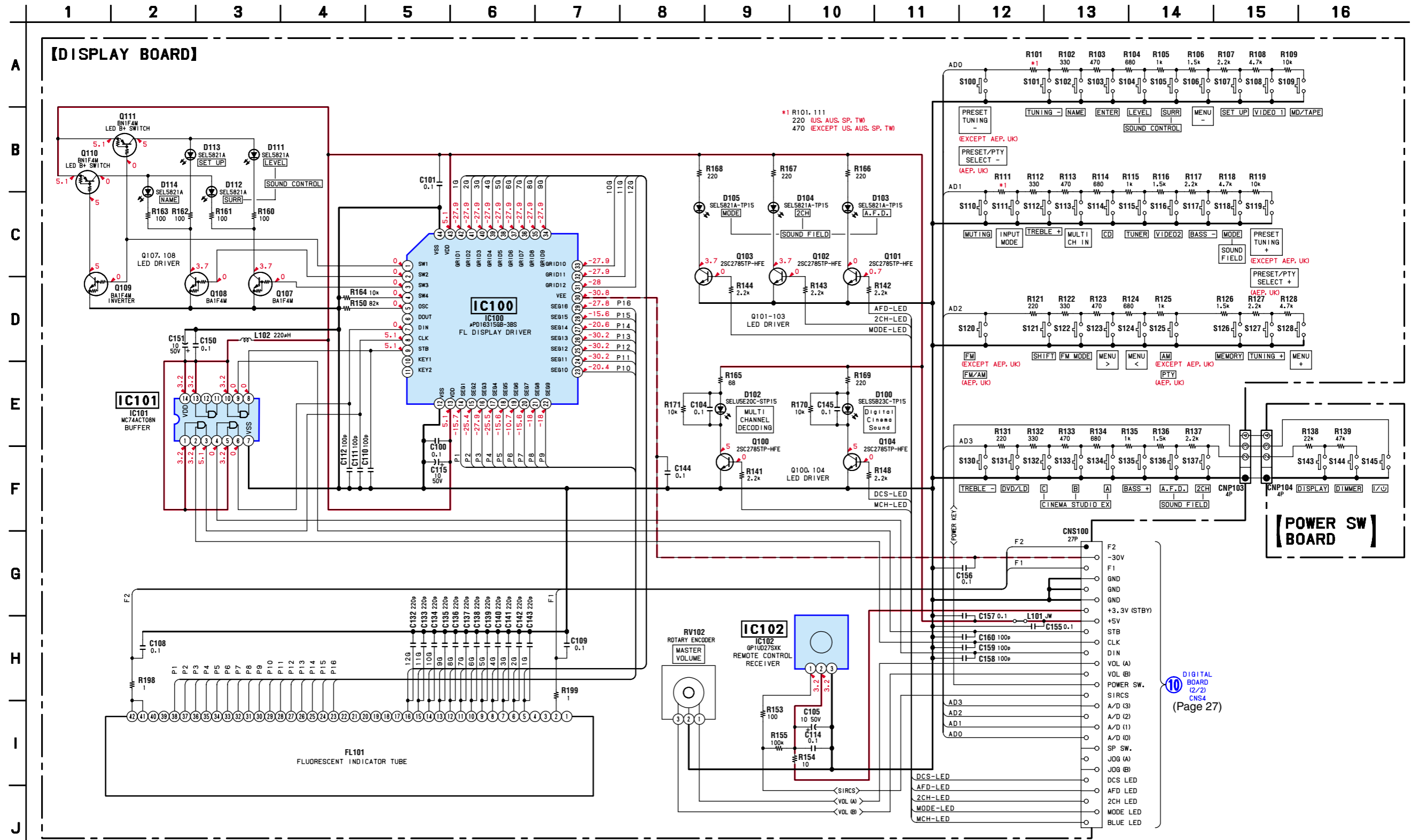

DIGITAL BOARD (2/2) CNS4 (Page 27)

4-18. PRINTED WIRING BOARDS — POWER SECTION — • Refer to page 15 for Circuit Boards Location and page 20 for Common Note on Printed Wiring Boards.

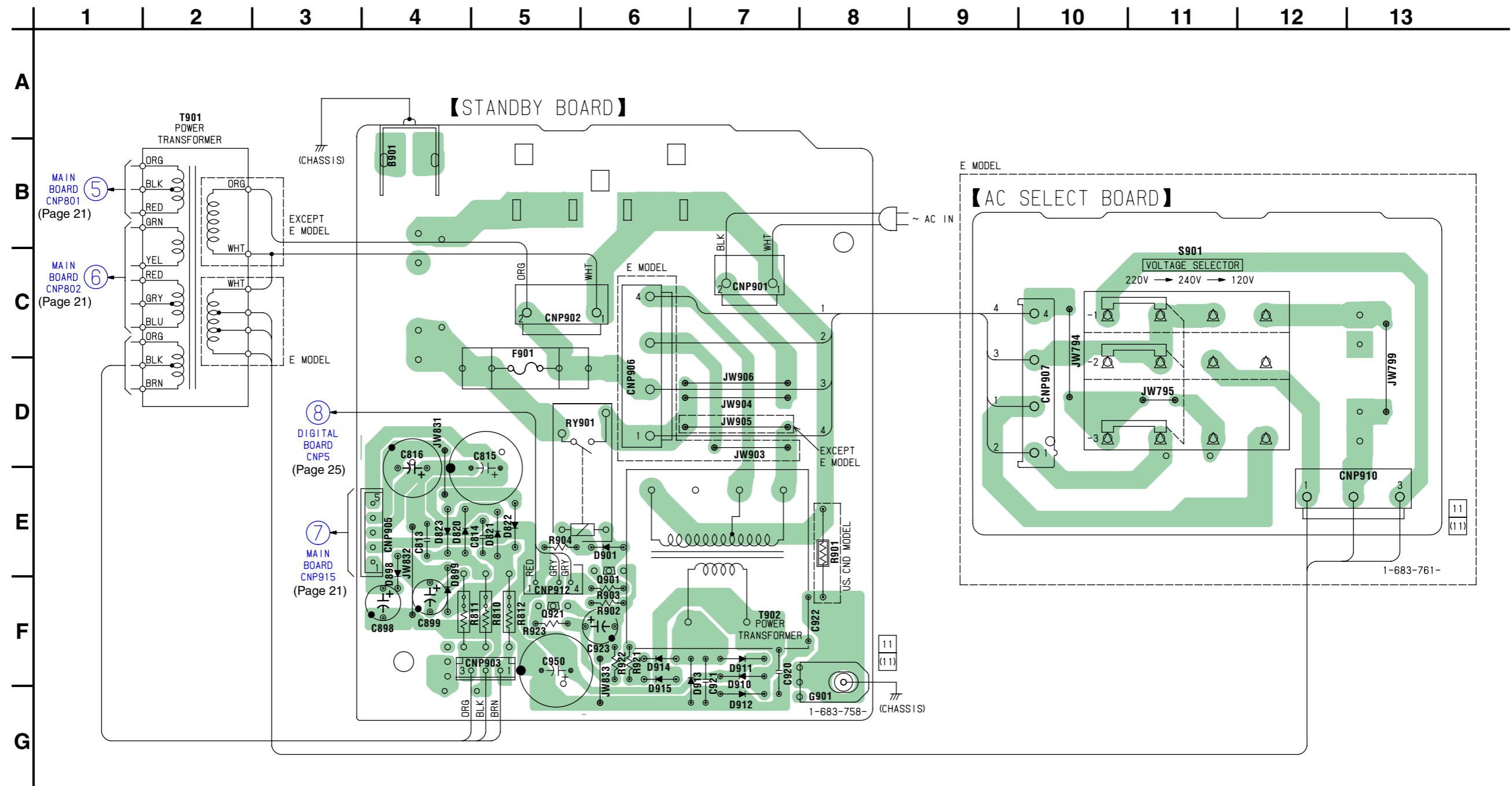

• Semiconductor Location

Ref. No.	Location
D820	E-4
D821	E-5
D822	E-5
D823	E-4
D898	E-4
D899	F-4
D901	E-6
D910	F-7
D911	F-7
D912	G-7
D913	F-7
D914	F-6
D915	F-6
Q901	F-6
Q921	F-5



4-19. SCHEMATIC DIAGRAM — POWER SECTION — • Refer to page 20 for Common Note on Schematic Diagram.

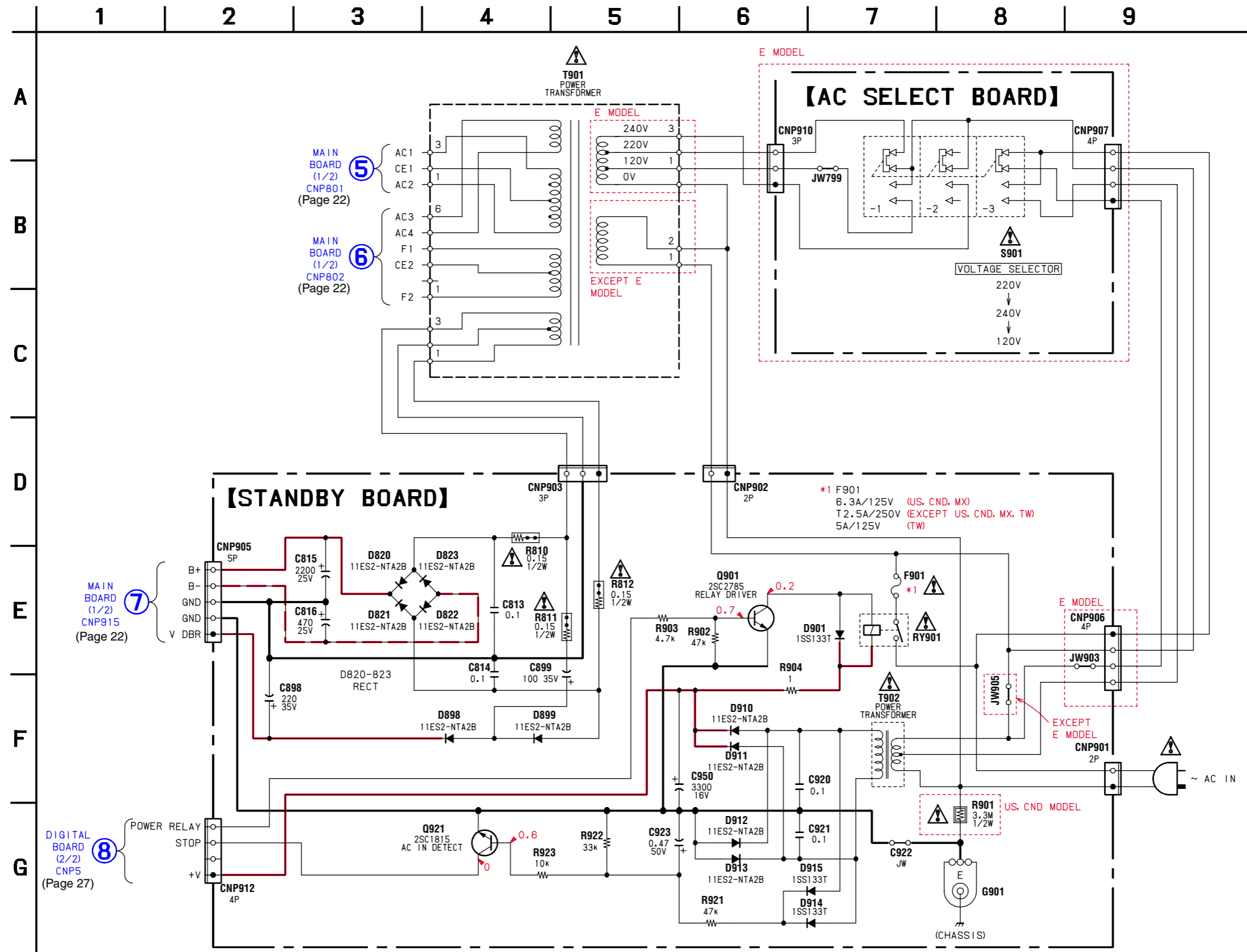

<p>The components identified by mark <math>\Delta</math> or dotted line with mark <math>\Delta</math> are critical for safety. Replace only with part number specified.</p>	<p>Les composants identifiés par une marque <math>\Delta</math> sont critiques pour la sécurité. Ne les remplacer que par une pièce portant le numéro spécifié.</p>	<p>以阴影和 <math>\Delta</math> 标志来识别的零部件，在安全方面具有关键性。因此只能以规定号码的零部件来更换。</p>
---	---	--

4-20. IC BLOCK DIAGRAMS

IC501 STK350-230 (MAIN BOARD (2/2))

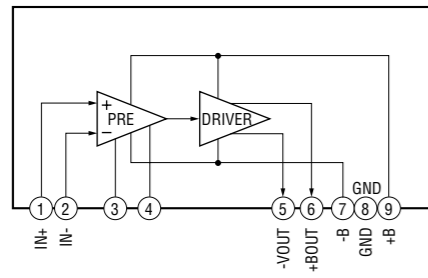

IC701  $\mu$ PC2581V (MAIN BOARD (2/2))  
IC702  $\mu$ PC2581V (MAIN BOARD (2/2))

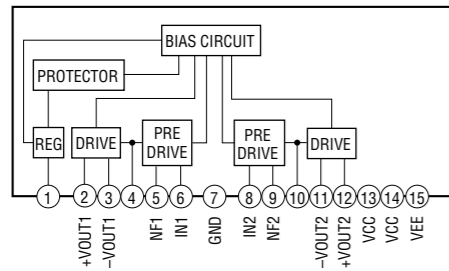

IC1101 LC89056W (DIGITAL BOARD (1/2))

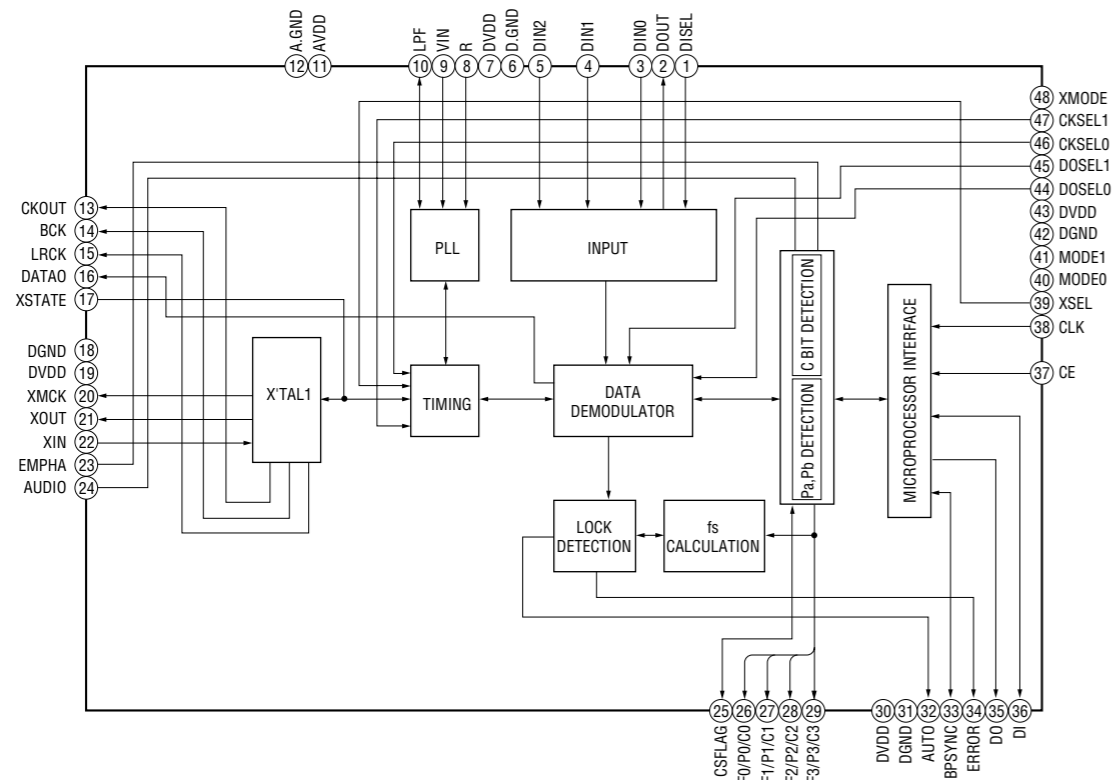

IC1501 AK4527 (DIGITAL BOARD (1/2))

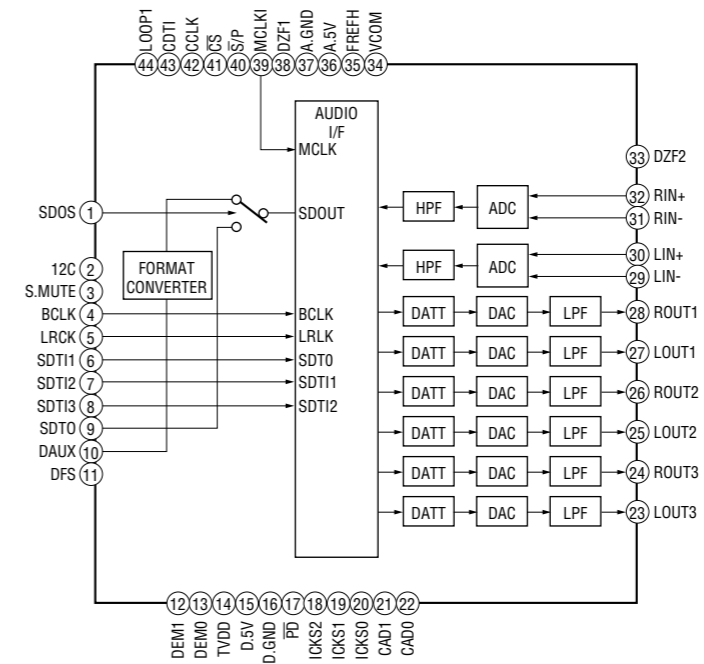

IC103 NJM2595 (VIDEO BOARD)

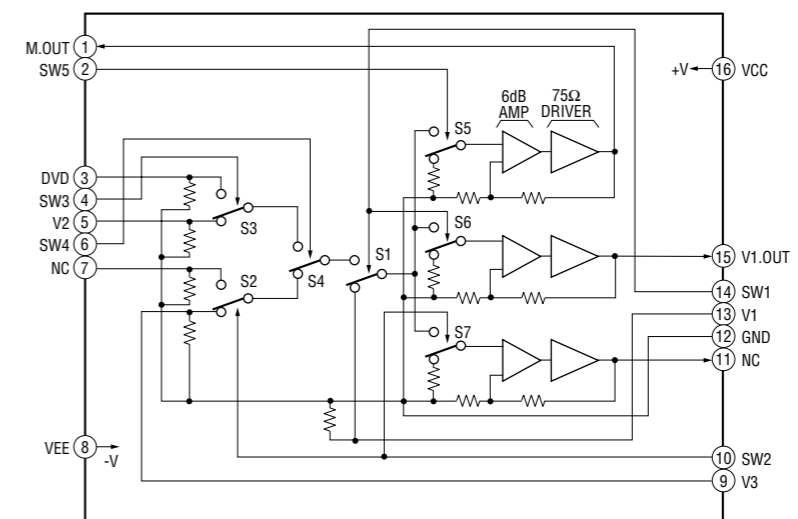

## SECTION 5 EXPLODED VIEWS

**NOTE:**

- The mechanical parts with no reference number in the exploded views are not supplied.
- Items marked "\*" are not stocked since they are seldom required for routine service. Some delay should be anticipated when ordering these items.
- Abbreviation  
 CND : Canadian model  
 AR : Argentina model  
 AUS : Australian model  
 CH : Chinese model  
 MX : Mexican model  
 SP : Singapore model  
 TW : Taiwan model

- XX and -X mean standardized parts, so they may have some difference from the original one.
- Color Indication of Appearance Parts  
 Example :  
 KNOB, BALANCE (WHITE) ... (RED)  
↑  
↑  
 Parts Color Cabinet's Color
- Accessories are given in the last of this parts list.

The components identified by mark ▲ or dotted line with mark ▲ are critical for safety. Replace only with part number specified.

Les composants identifiés par une marque ▲ sont critiques pour la sécurité. Ne les remplacer que par une pièce portant le numéro spécifié.

以阴影和▲标志来识别的零部件在安全方面具有关键性。因此只能以规定号码的零部件来更换。

### 5-1. CASE SECTION

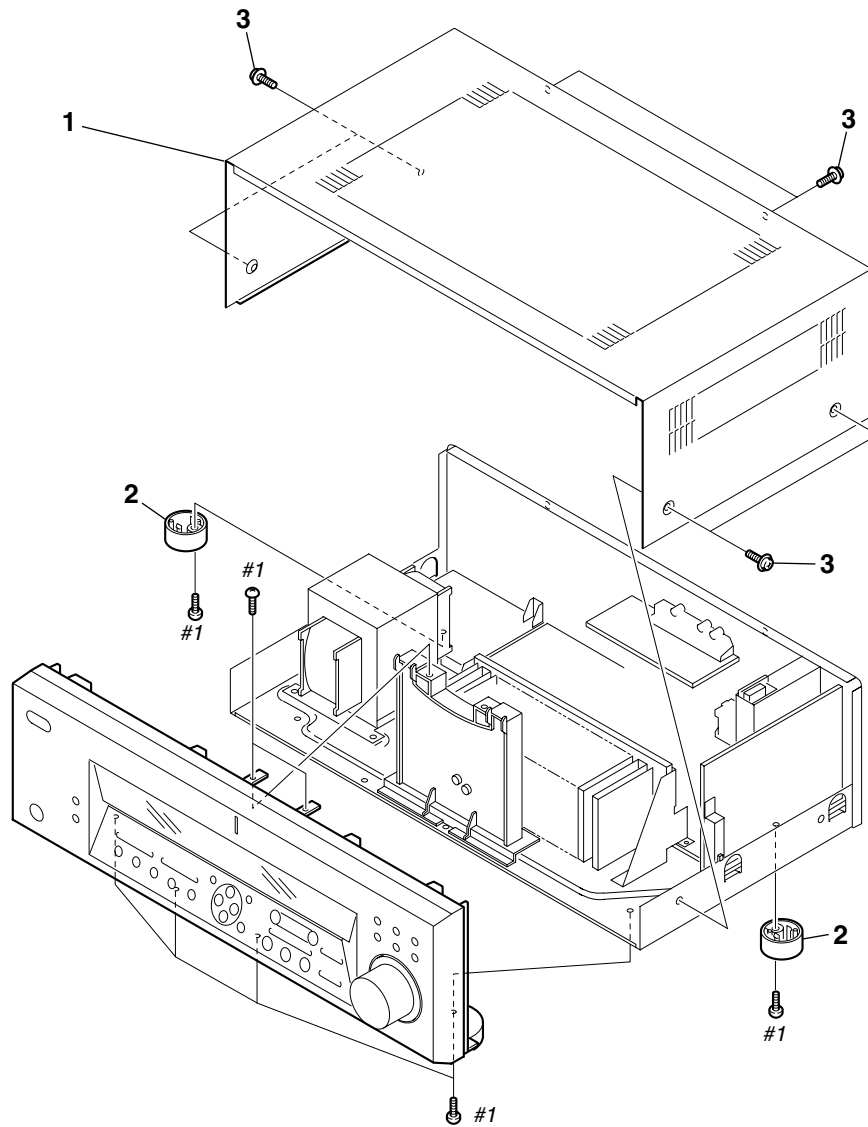

Ref. No.	Part No.	Description	Remark	Ref. No.	Part No.	Description	Remark
1	4-232-118-01	CASE (BLACK) (US,CND,AEP,UK,AUS,MX)		3	4-210-291-01	SCREW (CASE3 TP2) (BLACK)...(BLACK)	
1	4-232-118-21	CASE (SILVER) (AEP,UK,E,AUS,MX,AR)		3	4-210-291-11	SCREW (CASE3 TP2) (SILVER)...(SILVER,GOLD)	
1	4-232-118-41	CASE (GOLD) (CH,SP,TW)		#1	7-685-646-79	SCREW +BVTP 3X8 TYPE2 IT-3	
2	X-4953-448-1	FOOT ASSY					

5-2. FRONT PANEL SECTION

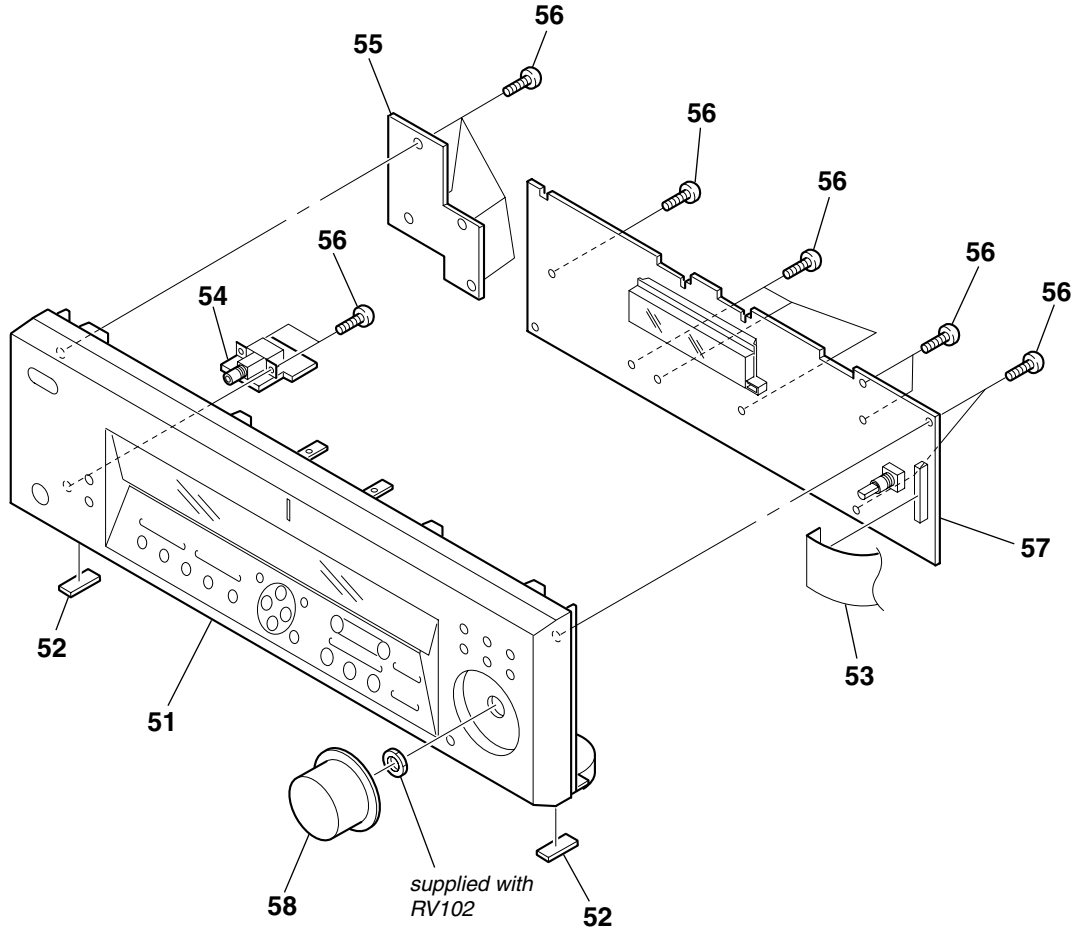

<u>Ref. No.</u>	<u>Part No.</u>	<u>Description</u>	<u>Remark</u>	<u>Ref. No.</u>	<u>Part No.</u>	<u>Description</u>	<u>Remark</u>
51	X-4954-423-1	PANEL ASSY, FRONT (BLACK) (CND)		53	1-773-250-11	WIRE (FLAT TYPE) (27 CORE)	
51	X-4954-424-1	PANEL ASSY, FRONT (BLACK) (MX)		54	1-683-763-11	HEADPHONE BOARD	
51	X-4954-425-1	PANEL ASSY, FRONT (SILVER) (E,MX,AR)		55	1-683-759-11	POWER SW BOARD	
51	X-4954-426-1	PANEL ASSY, FRONT (GOLD) (CH)		56	4-951-620-01	SCREW (2.6X8), +BVTP	
51	X-4954-427-1	PANEL ASSY, FRONT (BLACK) (AEP,UK)		57	A-4727-822-A	DISPLAY BOARD, COMPLETE (US,AUS,SP,TW)	
51	X-4954-428-1	PANEL ASSY, FRONT (SILVER) (AEP,UK)		57	A-4727-847-A	DISPLAY BOARD, COMPLETE (EXCEPT US,AUS,SP,TW)	
51	X-4954-461-1	PANEL ASSY, FRONT (BLACK) (US)		58	4-232-113-01	KNOB (VOL) (BLACK) (US,CND,AEP,UK,AUS,MX)	
51	X-4954-773-1	PANEL ASSY, FRONT (BLACK) (AUS)		58	4-232-113-12	KNOB (VOL) (SILVER) (AEP,UK,E,AUS,MX,AR)	
51	X-4954-774-1	PANEL ASSY, FRONT (SILVER) (AUS)		58	4-232-113-22	KNOB (VOL) (GOLD) (CH,SP,TW)	
51	X-4954-775-1	PANEL ASSY, FRONT (GOLD) (SP,TW)					
52	4-977-358-01	CUSHION					

5-3. CHASSIS SECTION-1

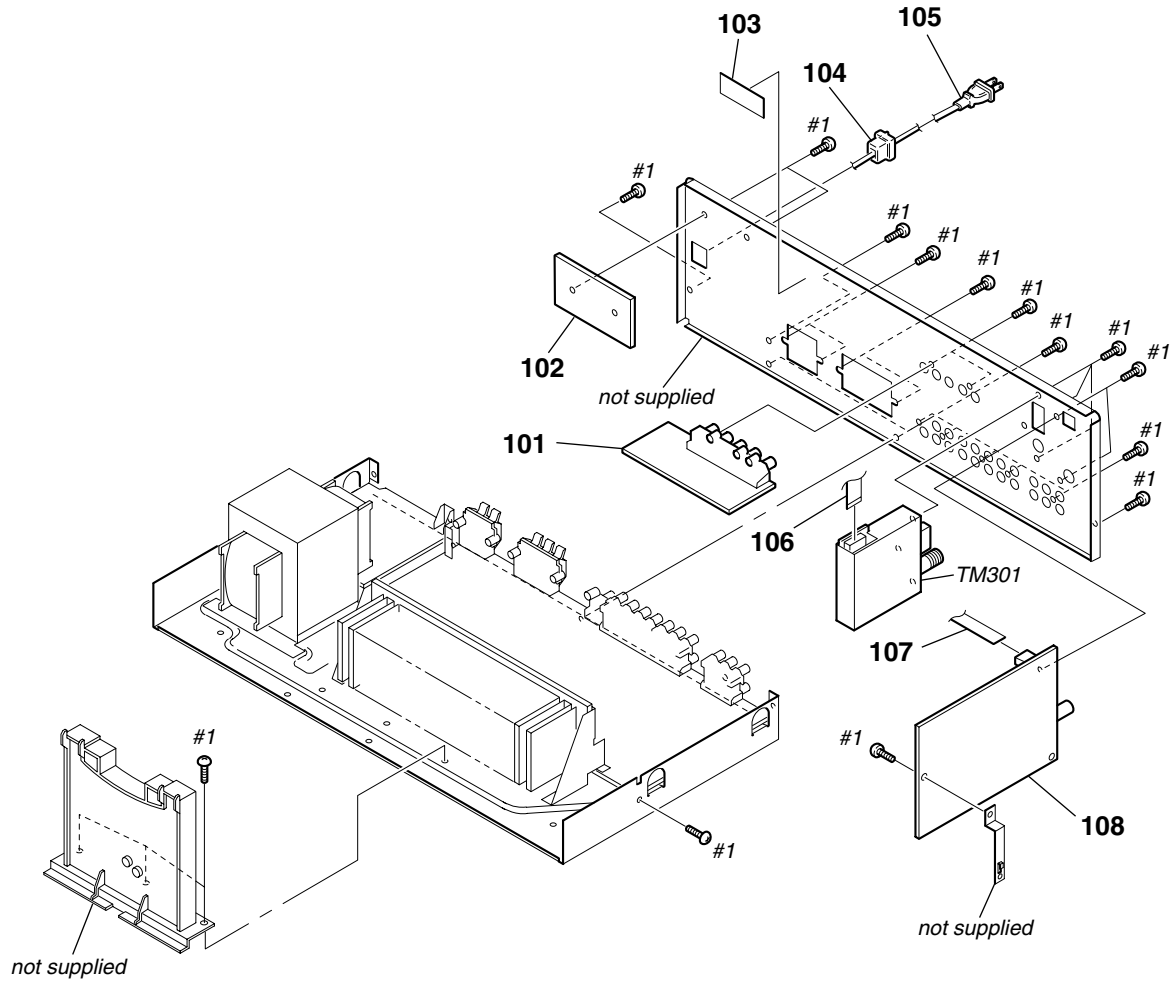

<p>The components identified by mark <math>\triangle</math> or dotted line with mark <math>\triangle</math> are critical for safety. Replace only with part number specified.</p>	<p>Les composants identifiés par une marque <math>\triangle</math> sont critiques pour la sécurité. Ne les remplacer que par une pièce portant le numéro spécifié.</p>	<p>以阴影和 <math>\triangle</math> 标志来识别的零部件，在安全方面具有关键性。因此只能以规定号码的零部件来更换。</p>
---	--	---

Ref. No.	Part No.	Description	Remark	Ref. No.	Part No.	Description	Remark
101	A-4727-815-A	VIDEO BOARD, COMPLETE (US)		108	A-4727-818-A	DIGITAL BOARD, COMPLETE (US)	
101	A-4727-840-A	VIDEO BOARD, COMPLETE (CND,MX)		108	A-4727-843-A	DIGITAL BOARD, COMPLETE (CND)	
101	A-4727-849-A	VIDEO BOARD, COMPLETE (AEP,UK,E,CH,AR)		108	A-4727-851-A	DIGITAL BOARD, COMPLETE (AEP,UK)	
101	A-4727-968-A	VIDEO BOARD, COMPLETE (AUS,SP,TW)		108	A-4727-996-A	DIGITAL BOARD, COMPLETE (E,MX)	
102	1-683-761-11	AC SELECT BOARD (E)		108	A-4728-002-A	DIGITAL BOARD, COMPLETE (CH,AR)	
* 103	3-703-044-26	LABEL, CAUTION (US)		108	A-4728-862-A	DIGITAL BOARD, COMPLETE (AUS)	
* 104	3-703-244-00	BUSHING (2104), CORD		108	A-4728-866-A	DIGITAL BOARD, COMPLETE (SP)	
$\triangle$ 105	1-696-847-11	CORD, POWER (AUS)		108	A-4728-870-A	DIGITAL BOARD, COMPLETE (TW)	
$\triangle$ 105	1-769-744-11	CORD, POWER (AEP,UK)		TM301	1-693-577-11	TUNER PACK (FM/AM) (ANTENNA) (E)	
$\triangle$ 105	1-777-071-21	CORD, POWER (E,SP,TW)		TM301	1-693-577-21	TUNER PACK (FM/AM) (ANTENNA) (US,CND,MX,TW)	
$\triangle$ 105	1-783-205-11	CORD, POWER (CH)		TM301	1-693-578-21	TUNER PACK (FM/AM) (ANTENNA) (AEP,UK)	
$\triangle$ 105	1-783-820-11	CORD, POWER (US,CND,MX)		TM301	1-693-580-21	TUNER PACK (FM/AM) (ANTENNA) (AUS,CH,SP,AR)	
$\triangle$ 105	1-783-941-12	CORD, POWER (AR)		#1	7-685-646-79	SCREW +BVTP 3X8 TYPE2 IT-3	
106	1-769-940-11	WIRE (FLAT TYPE) (11 CORE) (EXCEPT AEP,UK)					
106	1-773-004-11	WIRE (FLAT TYPE) (15 CORE) (AEP,UK)					
107	1-575-662-31	WIRE (FLAT TYPE) (5 CORE) (AUS,SP,TW)					
107	1-769-844-11	WIRE (FLAT TYPE) (5 CORE) (EXCEPT AUS,SP,TW)					

5-4. CHASSIS SECTION-2

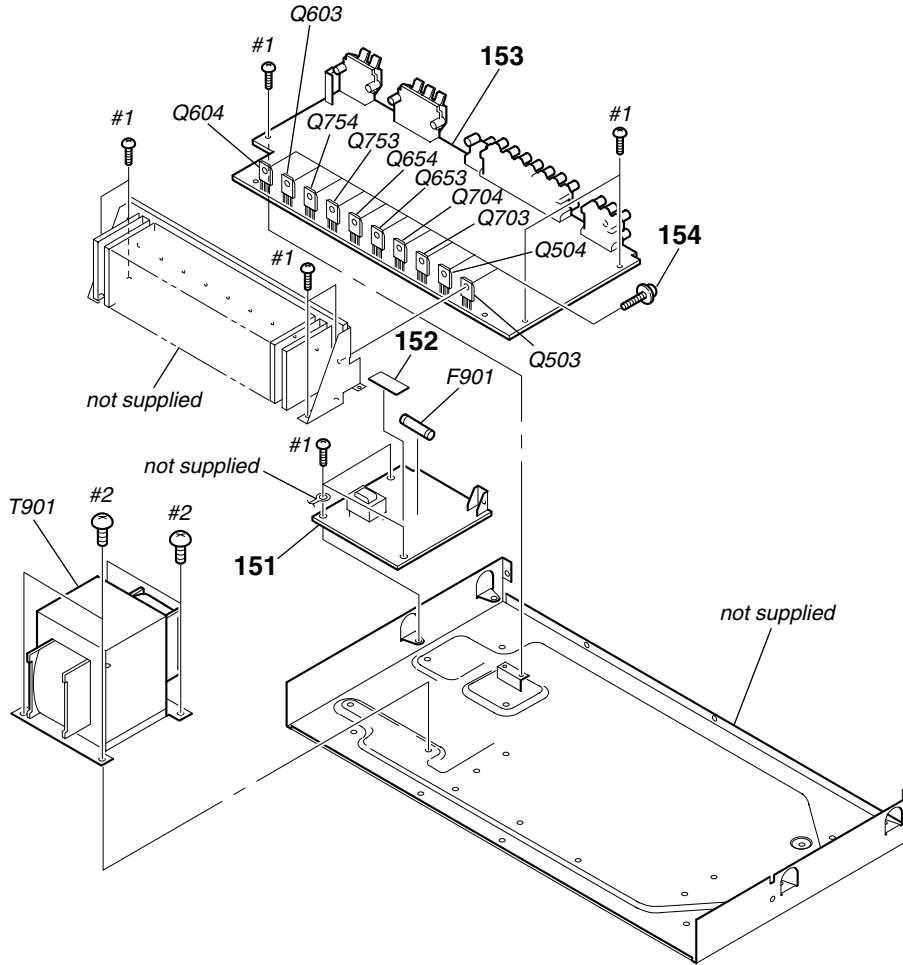

<p>The components identified by mark <math>\triangle</math> or dotted line with mark <math>\triangle</math> are critical for safety. Replace only with part number specified.</p>	<p>Les composants identifiés par une marque <math>\triangle</math> sont critiques pour la sécurité. Ne les remplacer que par une pièce portant le numéro spécifié.</p>	<p>以阴影和 <math>\triangle</math> 标志来识别的零部件，在安全方面具有关键性。因此只能以规定号码的零部件来更换。</p>
---	--	---

Ref. No.	Part No.	Description	Remark	Ref. No.	Part No.	Description	Remark
151	A-4727-816-A	STANDBY BOARD, COMPLETE (US)		Q503	8-749-010-25	TRANSISTOR MN2488-OPY-M	
151	A-4727-841-A	STANDBY BOARD, COMPLETE (CND)		Q504	8-749-010-26	TRANSISTOR MP1620-OPY-M	
151	A-4727-850-A	STANDBY BOARD, COMPLETE (AEP,UK,CH,AR)		Q603	8-749-010-25	TRANSISTOR MN2488-OPY-M	
151	A-4727-969-A	STANDBY BOARD, COMPLETE (AUS,SP)		Q604	8-749-010-26	TRANSISTOR MP1620-OPY-M	
151	A-4727-995-A	STANDBY BOARD, COMPLETE (MX)		Q653	8-749-010-25	TRANSISTOR MN2488-OPY-M	
151	A-4728-005-A	STANDBY BOARD, COMPLETE (E)		Q654	8-749-010-26	TRANSISTOR MP1620-OPY-M	
151	A-4728-869-A	STANDBY BOARD, COMPLETE (TW)		Q703	8-749-010-25	TRANSISTOR MN2488-OPY-M	
152	3-701-946-27	LABEL, FUSE RATING (TW)		Q704	8-749-010-26	TRANSISTOR MP1620-OPY-M	
153	A-4727-811-A	MAIN BOARD, COMPLETE (US)		Q753	8-749-010-25	TRANSISTOR MN2488-OPY-M	
153	A-4727-836-A	MAIN BOARD, COMPLETE (CND)		Q754	8-749-010-26	TRANSISTOR MP1620-OPY-M	
153	A-4727-848-A	MAIN BOARD, COMPLETE (AEP,UK)		$\triangle$ T901	1-437-632-11	TRANSFORMER, POWER (US,MX)	
153	A-4727-998-A	MAIN BOARD, COMPLETE (E,MX,AR)		$\triangle$ T901	1-437-633-11	TRANSFORMER, POWER (AEP,UK,CH,SP,AR)	
153	A-4728-004-A	MAIN BOARD, COMPLETE (CH)		$\triangle$ T901	1-437-634-11	TRANSFORMER, POWER (CND)	
153	A-4728-861-A	MAIN BOARD, COMPLETE (AUS,SP,TW)		$\triangle$ T901	1-437-635-11	TRANSFORMER, POWER (E)	
154	3-905-609-01	SCREW (TRANSISTOR)		$\triangle$ T901	1-437-637-11	TRANSFORMER, POWER (AUS)	
$\triangle$ F901	1-532-464-31	FUSE (T2.5A/250V) (EXCEPT US,CND,MX,TW)		$\triangle$ T901	1-437-638-11	TRANSFORMER, POWER (TW)	
$\triangle$ F901	1-576-109-11	FUSE (5A/125V) (TW)		#1	7-685-646-79	SCREW +BVPT 3X8 TYPE2 IT-3	
$\triangle$ F901	1-576-193-11	FUSE (6.3A/125V) (US,CND,MX)		#2	7-685-880-09	SCREW +BVTT 4X6 (S)	

## SECTION 6 ELECTRICAL PARTS LIST

AC SELECT

DIGITAL

## NOTE:

- Due to standardization, replacements in the parts list may be different from the parts specified in the diagrams or the components used on the set.
- -XX and -X mean standardized parts, so they may have some difference from the original one.
- RESISTORS  
All resistors are in ohms.  
METAL: Metal-film resistor.  
METAL OXIDE: Metal oxide-film resistor.  
F: nonflammable
- Items marked "\*" are not stocked since they are seldom required for routine service. Some delay should be anticipated when ordering these items.

- SEMICONDUCTORS  
In each case, u :  $\mu$ , for example:  
uA.. :  $\mu$ A.. uPA.. :  $\mu$ PA..  
uPB.. :  $\mu$ PB.. uPC.. :  $\mu$ PC.. uPD.. :  $\mu$ PD..
- CAPACITORS  
uF :  $\mu$ F
- COILS  
uH :  $\mu$ H
- Abbreviation  
CND : Canadian model  
AR : Argentina model  
AUS : Australian model  
CH : Chinese model  
MX : Mexican model  
SP : Singapore model  
TW : Taiwan model

The components identified by mark  $\Delta$  or dotted line with mark  $\Delta$  are critical for safety.  
Replace only with part number specified.

Les composants identifiés par une marque  $\Delta$  sont critiques pour la sécurité.  
Ne les remplacer que par une pièce portant le numéro spécifié.

以阴影和  $\Delta$  标志来识别的零部件在安全方面具有关键性。因此只能以规定号码的零部件来更换。

When indicating parts by reference number, please include the board.

Ref. No.	Part No.	Description	Remark	Ref. No.	Part No.	Description	Remark
	1-683-761-11	AC SELECT BOARD (E) *****					
		< CONNECTOR >					
* CNP910	1-564-687-11	PIN, CONNECTOR 3P (E)  < SWITCH >					
$\Delta$ S901	1-571-437-21	SWITCH, POWER VOLTAGE CHANGE (VOLTAGE SELECTOR) (E) *****					
	A-4727-818-A	DIGITAL BOARD, COMPLETE (US)					
	A-4727-843-A	DIGITAL BOARD, COMPLETE (CND)					
	A-4727-851-A	DIGITAL BOARD, COMPLETE (AEP,UK)					
	A-4727-996-A	DIGITAL BOARD, COMPLETE (E,MX)					
	A-4728-002-A	DIGITAL BOARD, COMPLETE (CH,AR)					
	A-4728-862-A	DIGITAL BOARD, COMPLETE (AUS)					
	A-4728-866-A	DIGITAL BOARD, COMPLETE (SP)					
	A-4728-870-A	DIGITAL BOARD, COMPLETE (TW) *****					
	7-685-646-79	SCREW +BVTP 3X8 TYPE2 IT-3  < CAPACITOR >					
	C1101	1-164-156-11 CERAMIC CHIP	0.1uF	25V			
	C1102	1-126-947-11 ELECT	47uF	20%	16V		
	C1103	1-164-156-11 CERAMIC CHIP	0.1uF		25V		
	C1104	1-162-974-11 CERAMIC CHIP	0.01uF		50V		
	C1105	1-126-947-11 ELECT	47uF	20%	16V		
	C1106	1-164-156-11 CERAMIC CHIP	0.1uF		25V		
	C1107	1-162-974-11 CERAMIC CHIP	0.01uF		50V		
	C1108	1-164-156-11 CERAMIC CHIP	0.1uF		25V		
	C1109	1-162-918-11 CERAMIC CHIP	18PF	5%	50V		
	C1110	1-162-918-11 CERAMIC CHIP	18PF	5%	50V		
	C1111	1-164-156-11 CERAMIC CHIP	0.1uF		25V		
	C1112	1-162-974-11 CERAMIC CHIP	0.01uF		50V		
	C1113	1-164-156-11 CERAMIC CHIP	0.1uF		25V		
	C1114	1-162-905-11 CERAMIC CHIP	1PF	0.25PF	50V		
	C1115	1-162-923-11 CERAMIC CHIP	47PF	5%	50V		
	C1116	1-126-935-11 ELECT	470uF	20%	16V		
	C1117	1-164-156-11 CERAMIC CHIP	0.1uF		25V		
	C1118	1-115-416-11 CERAMIC CHIP	0.001uF	5%	25V		
	C1119	1-126-965-11 ELECT	22uF	20%	50V		
	C1121	1-164-156-11 CERAMIC CHIP	0.1uF		25V		
	C1124	1-164-156-11 CERAMIC CHIP	0.1uF		25V		
	C1126	1-126-964-11 ELECT	10uF	20%	50V		
	C1127	1-164-156-11 CERAMIC CHIP	0.1uF		25V		
	C1129	1-115-416-11 CERAMIC CHIP	0.001uF	5%	25V		
	C1130	1-164-156-11 CERAMIC CHIP	0.1uF		25V		
	C1131	1-162-927-11 CERAMIC CHIP	100PF	5%	50V		
	C1201	1-164-156-11 CERAMIC CHIP	0.1uF		25V		
	C1202	1-164-156-11 CERAMIC CHIP	0.1uF		25V		
	C1203	1-164-156-11 CERAMIC CHIP	0.1uF		25V		
	C1204	1-164-156-11 CERAMIC CHIP	0.1uF		25V		
	C1205	1-164-156-11 CERAMIC CHIP	0.1uF		25V		
	C1206	1-164-156-11 CERAMIC CHIP	0.1uF		25V		
	C1207	1-164-156-11 CERAMIC CHIP	0.1uF		25V		
	C1208	1-164-156-11 CERAMIC CHIP	0.1uF		25V		
	C1209	1-164-156-11 CERAMIC CHIP	0.1uF		25V		
	C1210	1-164-156-11 CERAMIC CHIP	0.1uF		25V		
	C1211	1-126-935-11 ELECT	470uF	20%	10V		
	C1212	1-126-935-11 ELECT	470uF	20%	10V		
	C1213	1-164-156-11 CERAMIC CHIP	0.1uF		25V		
	C1214	1-164-156-11 CERAMIC CHIP	0.1uF		25V		
	C1216	1-162-927-11 CERAMIC CHIP	100PF	5%	50V		
	C1218	1-162-927-11 CERAMIC CHIP	100PF	5%	50V		
	C1219	1-164-156-11 CERAMIC CHIP	0.1uF		25V		
	C1220	1-162-927-11 CERAMIC CHIP	100PF	5%	50V		
	C1221	1-164-156-11 CERAMIC CHIP	0.1uF		25V		
	C1227	1-164-156-11 CERAMIC CHIP	0.1uF		25V		(AEP,UK)
	C1229	1-164-156-11 CERAMIC CHIP	0.1uF		25V		
	C1230	1-164-156-11 CERAMIC CHIP	0.1uF		25V		
	C1231	1-164-156-11 CERAMIC CHIP	0.1uF		25V		
	C1309	1-164-156-11 CERAMIC CHIP	0.1uF		25V		
	C1310	1-164-156-11 CERAMIC CHIP	0.1uF		25V		
	C1311	1-164-156-11 CERAMIC CHIP	0.1uF		25V		
	C1312	1-164-156-11 CERAMIC CHIP	0.1uF		25V		
	C1501	1-162-965-11 CERAMIC CHIP	0.0015uF	10%	50V		
	C1502	1-124-234-00 ELECT	22uF	20%	16V		
	C1503	1-164-156-11 CERAMIC CHIP	0.1uF		25V		
	C1504	1-126-964-11 ELECT	10uF	20%	50V		
	C1505	1-164-156-11 CERAMIC CHIP	0.1uF		25V		
	C1506	1-126-935-11 ELECT	470uF	20%	16V		
	C1507	1-126-964-11 ELECT	10uF	20%	50V		
	C1508	1-164-156-11 CERAMIC CHIP	0.1uF		25V		
	C1509	1-164-156-11 CERAMIC CHIP	0.1uF		25V		
	C1510	1-126-947-11 ELECT	47uF	20%	16V		
	C1511	1-162-974-11 CERAMIC CHIP	0.01uF		50V		
	C1512	1-162-995-11 CERAMIC CHIP	0.022uF		50V		

# STR-DE485/DE485E

## DIGITAL

Ref. No.	Part No.	Description	Remark	Ref. No.	Part No.	Description	Remark	
C1513	1-164-156-11	CERAMIC CHIP	0.1uF	25V	CNS3	1-784-923-11	PIN, CONNECTOR 7P	
C1514	1-164-156-11	CERAMIC CHIP	0.1uF	25V	CNS4	1-569-312-11	SOCKET, CONNECTOR (L TYPE) 27P	
C1515	1-126-964-11	ELECT	10uF	20%	50V	CNS7	1-569-060-11	SOCKET, CONNECTOR 11P (EXCEPT AEP,UK)
C1522	1-164-156-11	CERAMIC CHIP	0.1uF	25V	CNS7	1-569-321-11	SOCKET, CONNECTOR 15P (AEP,UK)	
C1523	1-162-995-11	CERAMIC CHIP	0.022uF	50V	CNS8	1-569-315-11	SOCKET, CONNECTOR 5P	
C1551	1-162-965-11	CERAMIC CHIP	0.0015uF	10%	50V	< DIODE >		
C1552	1-126-965-11	ELECT	22uF	20%	50V	D1001	8-719-016-74	DIODE 1SS352
C1601	1-164-156-11	CERAMIC CHIP	0.1uF	25V	D1101	8-719-016-74	DIODE 1SS352	
C1602	1-164-156-11	CERAMIC CHIP	0.1uF	25V	D1501	8-719-049-09	DIODE 1SS367-T3SONY	
C1603	1-164-156-11	CERAMIC CHIP	0.1uF	25V	D1502	8-719-049-09	DIODE 1SS367-T3SONY	
C1604	1-164-156-11	CERAMIC CHIP	0.1uF	25V	D1601	8-719-016-74	DIODE 1SS352	
C1605	1-164-156-11	CERAMIC CHIP	0.1uF	25V	D1905	8-719-053-18	DIODE 1SR154-400TE-25	
C1606	1-126-947-11	ELECT	47uF	20%	16V	D1906	8-719-053-18	DIODE 1SR154-400TE-25
C1607	1-164-156-11	CERAMIC CHIP	0.1uF	25V	D1907	8-719-053-18	DIODE 1SR154-400TE-25	
C1610	1-162-974-11	CERAMIC CHIP	0.01uF	50V	< FERRITE BEAD >			
C1611	1-162-974-11	CERAMIC CHIP	0.01uF	50V	FB1101	1-414-813-11	FERRITE, EMI (SMD)	
C1612	1-164-156-11	CERAMIC CHIP	0.1uF	25V	FB1102	1-414-813-11	FERRITE, EMI (SMD)	
C1613	1-162-995-11	CERAMIC CHIP	0.022uF	50V	FB1104	1-469-152-11	FERRITE, EMI (SMD)	
C1614	1-162-995-11	CERAMIC CHIP	0.022uF	50V	FB1105	1-469-152-11	FERRITE, EMI (SMD)	
C1615	1-162-995-11	CERAMIC CHIP	0.022uF	50V	FB1201	1-414-813-11	FERRITE, EMI (SMD)	
C1616	1-162-995-11	CERAMIC CHIP	0.022uF	50V	FB1202	1-414-813-11	FERRITE, EMI (SMD)	
C1617	1-162-974-11	CERAMIC CHIP	0.01uF	50V	FB1203	1-469-152-11	FERRITE, EMI (SMD)	
C1618	1-164-156-11	CERAMIC CHIP	0.1uF	25V	FB1204	1-469-152-11	FERRITE, EMI (SMD)	
C1619	1-164-156-11	CERAMIC CHIP	0.1uF	25V	FB1501	1-414-813-11	FERRITE, EMI (SMD)	
C1620	1-164-156-11	CERAMIC CHIP	0.1uF	25V	FB1502	1-414-813-11	FERRITE, EMI (SMD)	
C1626	1-164-156-11	CERAMIC CHIP	0.1uF	25V	FB1601	1-414-813-11	FERRITE, EMI (SMD)	
C1627	1-126-964-11	ELECT	10uF	20%	50V	FB1602	1-216-864-11	METAL CHIP 0 5% 1/16W
C1628	1-162-908-11	CERAMIC CHIP	3PF	0.25PF	50V	FB1603	1-216-864-11	METAL CHIP 0 5% 1/16W
C1629	1-162-908-11	CERAMIC CHIP	3PF	0.25PF	50V	< IC >		
C1631	1-164-156-11	CERAMIC CHIP	0.1uF	25V	IC1101	8-759-825-15	IC LC89056W-E	
C1632	1-164-156-11	CERAMIC CHIP	0.1uF	25V	IC1102	8-759-242-70	IC TC7WU04F	
C1633	1-164-156-11	CERAMIC CHIP	0.1uF	25V	IC1105	8-749-019-26	IC TORX141 (DIGITAL OPTICAL VIDEO 2 IN)	
C1634	1-164-156-11	CERAMIC CHIP	0.1uF	25V	IC1201	8-759-698-76	IC CXD9617R	
C1635	1-164-156-11	CERAMIC CHIP	0.1uF	25V	IC1202	6-700-983-01	IC IS61LV6416-15T(ICSI)	
C1905	1-164-156-11	CERAMIC CHIP	0.1uF	25V	IC1501	8-759-657-47	IC AK4527	
C1906	1-126-935-11	ELECT	470uF	20%	16V	IC1502	8-759-710-97	IC NJM4565M-D
C1908	1-126-935-11	ELECT	470uF	20%	16V	IC1503	8-759-701-75	IC NJM7805FA
C1909	1-164-156-11	CERAMIC CHIP	0.1uF	25V	IC1552	8-759-710-97	IC NJM4565M-D	
C1910	1-126-935-11	ELECT	470uF	20%	16V	IC1601	6-801-261-01	IC MB90478PF-G-120-BND
C1911	1-164-156-11	CERAMIC CHIP	0.1uF	25V	IC1602	8-759-714-20	IC S-80929ANMP-DDS-T2	
C1912	1-126-935-11	ELECT	470uF	20%	16V	IC1604	8-759-641-86	IC BR24C16F-E2
C1913	1-164-156-11	CERAMIC CHIP	0.1uF	25V	IC1901	6-701-887-01	IC SI-3001KWF	
C1914	1-126-947-11	ELECT	47uF	20%	16V	IC1902	8-759-656-35	IC NJM7810FA
C1915	1-126-947-11	ELECT	47uF	20%	16V	IC1903	8-759-647-11	IC uPC2905HF
C1916	1-164-156-11	CERAMIC CHIP	0.1uF	25V	IC1904	8-759-647-10	IC uPC2933HF	
< CONNECTOR >				IC1905	8-759-647-10	IC uPC2933HF (AEP,UK)		
CNP5	1-779-978-11	PIN, CONNECTOR 3P	< JACK >		J1101	1-784-431-11	JACK, PIN 1P (DIGITAL DVD/LD IN COAXIAL)	
CNP6	1-784-928-11	PIN, CONNECTOR 13P						
CNS1	1-573-829-11	CONNECTOR, BOARD TO BOARD 15P						
CNS2	1-784-041-41	CONNECTOR, BOARD TO BOARD 9P						



Ref. No.	Part No.	Description			Remark	Ref. No.	Part No.	Description			Remark	
		< JUMPER RESISTOR >										
JR1103	1-216-864-11	METAL CHIP	0	5%	1/16W	R1209	1-216-809-11	METAL CHIP	100	5%	1/16W	
JR1104	1-216-864-11	METAL CHIP	0	5%	1/16W	R1210	1-216-833-11	METAL CHIP	10K	5%	1/16W	
JR1110	1-216-295-11	SHORT	0			R1212	1-216-809-11	METAL CHIP	100	5%	1/16W	
JR1111	1-216-864-11	METAL CHIP	0	5%	1/16W	R1213	1-216-809-11	METAL CHIP	100	5%	1/16W	
JR1112	1-216-864-11	METAL CHIP	0	5%	1/16W (EXCEPT AEP,UK)	R1214	1-216-809-11	METAL CHIP	100	5%	1/16W	
JR1113	1-216-864-11	METAL CHIP	0	5%	1/16W (EXCEPT AEP,UK)	R1215	1-216-809-11	METAL CHIP	100	5%	1/16W	
JR1114	1-216-864-11	METAL CHIP	0	5%	1/16W (EXCEPT AEP,UK)	R1216	1-216-809-11	METAL CHIP	100	5%	1/16W	
JR1115	1-216-864-11	METAL CHIP	0	5%	1/16W	R1217	1-216-809-11	METAL CHIP	100	5%	1/16W	
JR1116	1-216-295-11	SHORT	0			R1218	1-216-809-11	METAL CHIP	100	5%	1/16W	
JR1121	1-216-864-11	METAL CHIP	0	5%	1/16W	R1219	1-216-809-11	METAL CHIP	100	5%	1/16W	
JR1122	1-216-864-11	METAL CHIP	0	5%	1/16W	R1220	1-216-809-11	METAL CHIP	100	5%	1/16W	
L1901	1-216-864-11	METAL CHIP	0	5%	1/16W	R1221	1-216-809-11	METAL CHIP	100	5%	1/16W	
		< TRANSISTOR >					R1222	1-216-809-11	METAL CHIP	100	5%	1/16W
Q1601	8-729-027-43	TRANSISTOR	DTC114EKA-T146			R1304	1-216-841-11	METAL CHIP	47K	5%	1/16W	
Q1602	8-729-230-49	TRANSISTOR	2SC2712-YG			R1305	1-216-841-11	METAL CHIP	47K	5%	1/16W	
		< RESISTOR >					R1308	1-216-821-11	METAL CHIP	1K	5%	1/16W
R1100	1-216-857-11	METAL CHIP	1M	5%	1/16W	R1314	1-216-864-11	METAL CHIP	0	5%	1/16W	
R1101	1-216-833-11	METAL CHIP	10K	5%	1/16W	R1364	1-216-864-11	METAL CHIP	0	5%	1/16W	
R1102	1-216-833-11	METAL CHIP	10K	5%	1/16W	R1501	1-216-815-11	METAL CHIP	330	5%	1/16W	
R1103	1-216-809-11	METAL CHIP	100	5%	1/16W	R1502	1-216-833-11	METAL CHIP	10K	5%	1/16W	
R1104	1-216-809-11	METAL CHIP	100	5%	1/16W	R1503	1-216-833-11	METAL CHIP	10K	5%	1/16W	
R1105	1-216-829-11	METAL CHIP	4.7K	5%	1/16W	R1504	1-216-815-11	METAL CHIP	330	5%	1/16W	
R1106	1-216-839-11	METAL CHIP	33K	5%	1/16W	R1505	1-216-825-11	METAL CHIP	2.2K	5%	1/16W	
R1107	1-216-830-11	METAL CHIP	5.6K	5%	1/16W	R1506	1-216-833-11	METAL CHIP	10K	5%	1/16W	
R1108	1-216-809-11	METAL CHIP	100	5%	1/16W	R1507	1-216-829-11	METAL CHIP	4.7K	5%	1/16W	
R1109	1-216-809-11	METAL CHIP	100	5%	1/16W	R1508	1-216-845-11	METAL CHIP	100K	5%	1/16W	
R1110	1-216-821-11	METAL CHIP	1K	5%	1/16W	R1509	1-216-809-11	METAL CHIP	100	5%	1/16W	
R1111	1-216-821-11	METAL CHIP	1K	5%	1/16W	R1516	1-216-864-11	METAL CHIP	0	5%	1/16W	
R1112	1-216-809-11	METAL CHIP	100	5%	1/16W	R1517	1-216-864-11	METAL CHIP	0	5%	1/16W	
R1113	1-216-821-11	METAL CHIP	1K	5%	1/16W	R1518	1-216-864-11	METAL CHIP	0	5%	1/16W	
R1114	1-216-809-11	METAL CHIP	100	5%	1/16W	R1519	1-216-864-11	METAL CHIP	0	5%	1/16W	
R1115	1-216-833-11	METAL CHIP	10K	5%	1/16W	R1520	1-216-864-11	METAL CHIP	0	5%	1/16W	
R1116	1-218-285-11	RES-CHIP	75	5%	1/10W	R1521	1-216-864-11	METAL CHIP	0	5%	1/16W	
R1117	1-216-821-11	METAL CHIP	1K	5%	1/16W	R1551	1-216-815-11	METAL CHIP	330	5%	1/16W	
R1118	1-216-854-11	METAL CHIP	560K	5%	1/16W	R1552	1-216-833-11	METAL CHIP	10K	5%	1/16W	
R1119	1-216-837-11	METAL CHIP	22K	5%	1/16W	R1553	1-216-833-11	METAL CHIP	10K	5%	1/16W	
R1121	1-216-809-11	METAL CHIP	100	5%	1/16W	R1554	1-216-815-11	METAL CHIP	330	5%	1/16W	
R1124	1-216-809-11	METAL CHIP	100	5%	1/16W	R1555	1-216-825-11	METAL CHIP	2.2K	5%	1/16W	
R1201	1-216-833-11	METAL CHIP	10K	5%	1/16W	R1556	1-216-833-11	METAL CHIP	10K	5%	1/16W	
R1202	1-216-809-11	METAL CHIP	100	5%	1/16W	R1557	1-216-829-11	METAL CHIP	4.7K	5%	1/16W	
R1203	1-216-833-11	METAL CHIP	10K	5%	1/16W	R1600	1-216-829-11	METAL CHIP	4.7K	5%	1/16W	
R1204	1-216-821-11	METAL CHIP	1K	5%	1/16W	R1601	1-216-821-11	METAL CHIP	1K	5%	1/16W	
R1205	1-216-809-11	METAL CHIP	100	5%	1/16W	R1602	1-216-829-11	METAL CHIP	4.7K	5%	1/16W	
R1206	1-216-809-11	METAL CHIP	100	5%	1/16W	R1603	1-216-821-11	METAL CHIP	1K	5%	1/16W	
R1207	1-216-809-11	METAL CHIP	100	5%	1/16W	R1604	1-216-809-11	METAL CHIP	100	5%	1/16W	
R1208	1-216-809-11	METAL CHIP	100	5%	1/16W	R1605	1-216-809-11	METAL CHIP	100	5%	1/16W	
						R1606	1-216-821-11	METAL CHIP	1K	5%	1/16W	
						R1607	1-216-821-11	METAL CHIP	1K	5%	1/16W	
						R1608	1-216-821-11	METAL CHIP	1K	5%	1/16W	
						R1609	1-216-821-11	METAL CHIP	1K	5%	1/16W	
						R1610	1-216-821-11	METAL CHIP	1K	5%	1/16W	
						R1611	1-216-821-11	METAL CHIP	1K	5%	1/16W	
						R1612	1-216-821-11	METAL CHIP	1K	5%	1/16W	

# STR-DE485/DE485E

## DIGITAL

Ref. No.	Part No.	Description	Remark
R1613	1-216-821-11	METAL CHIP	1K 5% 1/16W
R1614	1-216-821-11	METAL CHIP	1K 5% 1/16W
R1615	1-216-821-11	METAL CHIP	1K 5% 1/16W
R1617	1-216-809-11	METAL CHIP	100 5% 1/16W
R1618	1-216-809-11	METAL CHIP	100 5% 1/16W
R1619	1-216-809-11	METAL CHIP	100 5% 1/16W
R1620	1-216-833-11	METAL CHIP	10K 5% 1/16W
R1621	1-216-821-11	METAL CHIP	1K 5% 1/16W
R1622	1-216-833-11	METAL CHIP	10K 5% 1/16W
R1623	1-216-821-11	METAL CHIP	1K 5% 1/16W
R1624	1-216-833-11	METAL CHIP	10K 5% 1/16W
R1625	1-216-833-11	METAL CHIP	10K 5% 1/16W
R1626	1-216-833-11	METAL CHIP	10K 5% 1/16W
R1627	1-216-833-11	METAL CHIP	10K 5% 1/16W
R1628	1-216-833-11	METAL CHIP	10K 5% 1/16W
R1629	1-216-833-11	METAL CHIP	10K 5% 1/16W
R1630	1-216-833-11	METAL CHIP	10K 5% 1/16W
R1631	1-216-829-11	METAL CHIP	4.7K 5% 1/16W
R1632	1-216-841-11	METAL CHIP	47K 5% 1/16W
R1633	1-216-841-11	METAL CHIP	47K 5% 1/16W
R1634	1-216-841-11	METAL CHIP	47K 5% 1/16W (EXCEPT US,CND)
R1635	1-216-833-11	METAL CHIP	10K 5% 1/16W
R1636	1-216-833-11	METAL CHIP	10K 5% 1/16W
R1637	1-216-833-11	METAL CHIP	10K 5% 1/16W
R1638	1-216-829-11	METAL CHIP	4.7K 5% 1/16W
R1639	1-216-821-11	METAL CHIP	1K 5% 1/16W
R1640	1-216-821-11	METAL CHIP	1K 5% 1/16W
R1641	1-216-821-11	METAL CHIP	1K 5% 1/16W
R1642	1-216-833-11	METAL CHIP	10K 5% 1/16W
R1643	1-216-821-11	METAL CHIP	1K 5% 1/16W
R1644	1-216-821-11	METAL CHIP	1K 5% 1/16W
R1645	1-216-821-11	METAL CHIP	1K 5% 1/16W
R1646	1-216-821-11	METAL CHIP	1K 5% 1/16W
R1647	1-216-821-11	METAL CHIP	1K 5% 1/16W
R1648	1-216-821-11	METAL CHIP	1K 5% 1/16W
R1649	1-216-821-11	METAL CHIP	1K 5% 1/16W
R1650	1-216-833-11	METAL CHIP	10K 5% 1/16W
R1651	1-216-833-11	METAL CHIP	10K 5% 1/16W
R1654	1-216-833-11	METAL CHIP	10K 5% 1/16W
R1655	1-216-833-11	METAL CHIP	10K 5% 1/16W
R1656	1-216-833-11	METAL CHIP	10K 5% 1/16W
R1657	1-216-833-11	METAL CHIP	10K 5% 1/16W
R1658	1-216-809-11	METAL CHIP	100 5% 1/16W
R1659	1-216-833-11	METAL CHIP	10K 5% 1/16W
R1661	1-216-833-11	METAL CHIP	10K 5% 1/16W
R1662	1-216-827-11	METAL CHIP	3.3K 5% 1/16W
R1663	1-216-827-11	METAL CHIP	3.3K 5% 1/16W
R1664	1-216-809-11	METAL CHIP	100 5% 1/16W
R1665	1-216-809-11	METAL CHIP	100 5% 1/16W
R1666	1-216-833-11	METAL CHIP	10K 5% 1/16W
R1667	1-216-821-11	METAL CHIP	1K 5% 1/16W
R1668	1-216-830-11	METAL CHIP	5.6K 5% 1/16W

Ref. No.	Part No.	Description	Remark
R1669	1-216-829-11	METAL CHIP	4.7K 5% 1/16W
R1670	1-216-833-11	METAL CHIP	10K 5% 1/16W
R1673	1-216-821-11	METAL CHIP	1K 5% 1/16W
R1674	1-216-821-11	METAL CHIP	1K 5% 1/16W
R1676	1-216-821-11	METAL CHIP	1K 5% 1/16W
R1677	1-216-821-11	METAL CHIP	1K 5% 1/16W
R1678	1-216-821-11	METAL CHIP	1K 5% 1/16W
R1679	1-216-821-11	METAL CHIP	1K 5% 1/16W
R1682	1-216-845-11	METAL CHIP	100K 5% 1/16W
R1684	1-216-821-11	METAL CHIP	1K 5% 1/16W
R1685	1-216-821-11	METAL CHIP	1K 5% 1/16W
R1686	1-216-821-11	METAL CHIP	1K 5% 1/16W
R1687	1-216-833-11	METAL CHIP	10K 5% 1/16W
R1688	1-216-864-11	METAL CHIP	0 5% 1/16W
R1689	1-216-833-11	METAL CHIP	10K 5% 1/16W
R1690	1-216-833-11	METAL CHIP	10K 5% 1/16W
R1694	1-216-821-11	METAL CHIP	1K 5% 1/16W
R1697	1-216-825-11	METAL CHIP	2.2K 5% 1/16W (AEP,UK)
R1697	1-216-829-11	METAL CHIP	4.7K 5% 1/16W (CH,SP,AR)
R1697	1-216-833-11	METAL CHIP	10K 5% 1/16W (E,AUS,MX)
R1697	1-216-837-11	METAL CHIP	22K 5% 1/16W (TW)
R1697	1-216-864-11	METAL CHIP	0 5% 1/16W (US,CND)
R1698	1-216-829-11	METAL CHIP	4.7K 5% 1/16W
R1699	1-216-829-11	METAL CHIP	4.7K 5% 1/16W
R1703	1-216-833-11	METAL CHIP	10K 5% 1/16W
R1704	1-216-833-11	METAL CHIP	10K 5% 1/16W
R1705	1-216-809-11	METAL CHIP	100 5% 1/16W
R1706	1-216-833-11	METAL CHIP	10K 5% 1/16W
R1707	1-216-833-11	METAL CHIP	10K 5% 1/16W
R1708	1-216-833-11	METAL CHIP	10K 5% 1/16W
R1709	1-216-833-11	METAL CHIP	10K 5% 1/16W
R1710	1-216-809-11	METAL CHIP	100 5% 1/16W
R1711	1-216-809-11	METAL CHIP	100 5% 1/16W

< VIBRATOR >

- X1101 1-795-126-21 VIBRATOR, CRYSTAL (12.288MHz)
- X1201 1-795-297-21 VIBRATOR, CERAMIC (13.5MHz)
- X1601 1-795-318-11 VIBRATOR, CERAMIC (20MHz)

\*\*\*\*\*

Ref. No.	Part No.	Description	Remark	Ref. No.	Part No.	Description	Remark
	A-4727-822-A	DISPLAY BOARD, COMPLETE (US,AUS,SP,TW)		D113	8-719-046-39	LED SEL5821A-TP15 (SET UP)	
	A-4727-847-A	DISPLAY BOARD, COMPLETE (EXCEPT US,AUS,SP,TW)		D114	8-719-046-39	LED SEL5821A-TP15 (NAME)	
		*****				< FLUORESCENT INDICATOR >	
*	3-386-245-13	HOLDER (FL) (US,AUS,SP,TW)		FL101	1-518-718-11	INDICATOR TUBE, FLUORESCENT	
	3-386-245-21	HOLDER (FL) (EXCEPT US,AUS,SP,TW)				< IC >	
*	4-921-941-01	CUSHION (FL)		IC100	8-759-643-83	IC uPD16315GB-3BS	
		< CAPACITOR >		IC101	8-759-036-90	IC MC74ACT08N	
				IC102	6-600-055-01	IC GP1UD27SXX	
C100	1-164-159-11	CERAMIC	0.1uF 50V			< COIL >	
C101	1-164-159-11	CERAMIC	0.1uF 50V				
C104	1-164-159-11	CERAMIC	0.1uF 50V				
C105	1-126-795-11	ELECT	10uF 20% 50V				
C108	1-164-159-11	CERAMIC	0.1uF 50V	L102	1-408-088-00	INDUCTOR 220uH	
						< TRANSISTOR >	
C109	1-164-159-11	CERAMIC	0.1uF 50V	Q100	8-729-119-78	TRANSISTOR 2SC2785-HFE	
C110	1-128-809-11	CERAMIC	100PF 5% 50V	Q101	8-729-119-78	TRANSISTOR 2SC2785-HFE	
C111	1-128-809-11	CERAMIC	100PF 5% 50V	Q102	8-729-119-78	TRANSISTOR 2SC2785-HFE	
C112	1-128-809-11	CERAMIC	100PF 5% 50V	Q103	8-729-119-78	TRANSISTOR 2SC2785-HFE	
C114	1-164-159-11	CERAMIC	0.1uF 50V	Q104	8-729-119-78	TRANSISTOR 2SC2785-HFE	
				Q107	8-729-900-36	TRANSISTOR DTC124ES	
C115	1-126-795-11	ELECT	10uF 20% 50V	Q108	8-729-900-36	TRANSISTOR DTC124ES	
C132	1-128-813-11	CERAMIC	220PF 5% 50V	Q109	8-729-900-36	TRANSISTOR DTC124ES	
C133	1-128-813-11	CERAMIC	220PF 5% 50V	Q110	8-729-900-63	TRANSISTOR DTA124ES	
C134	1-128-813-11	CERAMIC	220PF 5% 50V	Q111	8-729-900-63	TRANSISTOR DTA124ES	
C135	1-128-813-11	CERAMIC	220PF 5% 50V			< RESISTOR >	
				R101	1-249-409-11	CARBON 220 5% 1/4W (US,AUS,SP,TW)	
C136	1-128-813-11	CERAMIC	220PF 5% 50V	R101	1-249-413-11	CARBON 470 5% 1/4W (EXCEPT US,AUS,SP,TW)	
C137	1-128-813-11	CERAMIC	220PF 5% 50V	R102	1-249-411-11	CARBON 330 5% 1/4W	
C138	1-128-813-11	CERAMIC	220PF 5% 50V	R103	1-249-413-11	CARBON 470 5% 1/4W	
C139	1-128-813-11	CERAMIC	220PF 5% 50V	R104	1-249-415-11	CARBON 680 5% 1/4W	
C140	1-128-813-11	CERAMIC	220PF 5% 50V	R105	1-249-417-11	CARBON 1K 5% 1/4W	
				R106	1-249-419-11	CARBON 1.5K 5% 1/4W	
C141	1-128-813-11	CERAMIC	220PF 5% 50V	R107	1-249-421-11	CARBON 2.2K 5% 1/4W	
C142	1-128-813-11	CERAMIC	220PF 5% 50V	R108	1-249-425-11	CARBON 4.7K 5% 1/4W	
C143	1-128-813-11	CERAMIC	220PF 5% 50V	R109	1-249-429-11	CARBON 10K 5% 1/4W	
C144	1-164-159-11	CERAMIC	0.1uF 50V				
C145	1-164-159-11	CERAMIC	0.1uF 50V	R111	1-249-409-11	CARBON 220 5% 1/4W (US,AUS,SP,TW)	
				R111	1-249-413-11	CARBON 470 5% 1/4W (EXCEPT US,AUS,SP,TW)	
C150	1-164-159-11	CERAMIC	0.1uF 50V	R112	1-249-411-11	CARBON 330 5% 1/4W	
C151	1-126-795-11	ELECT	10uF 20% 50V	R113	1-249-413-11	CARBON 470 5% 1/4W	
C155	1-164-159-11	CERAMIC	0.1uF 50V	R114	1-249-415-11	CARBON 680 5% 1/4W	
C156	1-164-159-11	CERAMIC	0.1uF 50V	R115	1-249-417-11	CARBON 1K 5% 1/4W	
C157	1-164-159-11	CERAMIC	0.1uF 50V	R116	1-249-419-11	CARBON 1.5K 5% 1/4W	
				R117	1-249-421-11	CARBON 2.2K 5% 1/4W	
C158	1-128-809-11	CERAMIC	100PF 5% 50V	R118	1-249-425-11	CARBON 4.7K 5% 1/4W	
C159	1-128-809-11	CERAMIC	100PF 5% 50V	R119	1-249-429-11	CARBON 10K 5% 1/4W	
C160	1-128-809-11	CERAMIC	100PF 5% 50V				
		< DIODE >		R121	1-249-409-11	CARBON 220 5% 1/4W	
D100	8-719-075-59	LED SELS5B23C-TP15 (Digital Cinema Sound)		R122	1-249-411-11	CARBON 330 5% 1/4W	
D102	8-719-072-82	LED SELU5E20C-STP15 (MULTI CHANNEL DECODING)					
D103	8-719-046-39	LED SEL5821A-TP15 (SOUND FIELD A.F.D.)					
D104	8-719-046-39	LED SEL5821A-TP15 (SOUND FIELD 2CH)					
D105	8-719-046-39	LED SEL5821A-TP15 (SOUND FIELD MODE)					
D111	8-719-046-39	LED SEL5821A-TP15 (SOUND CONTROL LEVEL)					
D112	8-719-046-39	LED SEL5821A-TP15 (SOUND CONTROL SURR)					

# STR-DE485/DE485E

<b>DISPLAY</b>	<b>HEADPHONE</b>
----------------	------------------

Ref. No.	Part No.	Description	Remark
R123	1-249-413-11	CARBON 470	5% 1/4W
R124	1-249-415-11	CARBON 680	5% 1/4W
R125	1-249-417-11	CARBON 1K	5% 1/4W
R126	1-249-419-11	CARBON 1.5K	5% 1/4W
R127	1-249-421-11	CARBON 2.2K	5% 1/4W
R128	1-249-425-11	CARBON 4.7K	5% 1/4W
R131	1-249-409-11	CARBON 220	5% 1/4W
R132	1-249-411-11	CARBON 330	5% 1/4W
R133	1-249-413-11	CARBON 470	5% 1/4W
R134	1-249-415-11	CARBON 680	5% 1/4W
R135	1-249-417-11	CARBON 1K	5% 1/4W
R136	1-249-419-11	CARBON 1.5K	5% 1/4W
R137	1-249-421-11	CARBON 2.2K	5% 1/4W
R141	1-249-421-11	CARBON 2.2K	5% 1/4W
R142	1-249-421-11	CARBON 2.2K	5% 1/4W
R143	1-249-421-11	CARBON 2.2K	5% 1/4W
R144	1-249-421-11	CARBON 2.2K	5% 1/4W
R148	1-249-421-11	CARBON 2.2K	5% 1/4W
R150	1-249-440-11	CARBON 82K	5% 1/4W
R153	1-247-807-31	CARBON 100	5% 1/4W
R154	1-249-393-11	CARBON 10	5% 1/4W
R155	1-249-441-11	CARBON 100K	5% 1/4W
R160	1-247-807-31	CARBON 100	5% 1/4W
R161	1-247-807-31	CARBON 100	5% 1/4W
R162	1-247-807-31	CARBON 100	5% 1/4W
R163	1-247-807-31	CARBON 100	5% 1/4W
R164	1-249-429-11	CARBON 10K	5% 1/4W
R165	1-249-403-11	CARBON 68	5% 1/4W
R166	1-249-409-11	CARBON 220	5% 1/4W
R167	1-249-409-11	CARBON 220	5% 1/4W
R168	1-249-409-11	CARBON 220	5% 1/4W
R169	1-249-409-11	CARBON 220	5% 1/4W
R170	1-249-429-11	CARBON 10K	5% 1/4W
R171	1-249-429-11	CARBON 10K	5% 1/4W
R175	1-249-393-11	CARBON 10	5% 1/4W
R198	1-249-381-11	CARBON 1	5% 1/4W
R199	1-249-381-11	CARBON 1	5% 1/4W
< ROTARY ENCODER >			
RV102	1-418-725-41	ENCODER, ROTARY (12 TYPE)	(MASTER VOLUME)
< SWITCH >			
S100	1-771-410-21	SWITCH, TACTILE (PRESET/PTY SELECT -)	(AEP,UK)
S100	1-771-410-21	SWITCH, TACTILE (PRESET TUNING -)	(EXCEPT AEP,UK)
S101	1-771-410-21	SWITCH, TACTILE (TUNING -)	
S102	1-771-410-21	SWITCH, TACTILE (NAME)	
S103	1-771-410-21	SWITCH, TACTILE (ENTER)	
S104	1-771-410-21	SWITCH, TACTILE (SOUND CONTROL LEVEL)	
S105	1-771-410-21	SWITCH, TACTILE (SOUND CONTROL SURR)	
S106	1-771-410-21	SWITCH, TACTILE (MENU -)	

Ref. No.	Part No.	Description	Remark
S107	1-771-410-21	SWITCH, TACTILE (SET UP)	
S108	1-771-410-21	SWITCH, TACTILE (VIDEO 1)	
S109	1-771-410-21	SWITCH, TACTILE (MD/TAPE)	
S110	1-771-410-21	SWITCH, TACTILE (MUTING)	
S111	1-771-410-21	SWITCH, TACTILE (INPUT MODE)	
S112	1-771-410-21	SWITCH, TACTILE (TREBLE +)	
S113	1-771-410-21	SWITCH, TACTILE (MULTI CH IN)	
S114	1-771-410-21	SWITCH, TACTILE (CD)	
S115	1-771-410-21	SWITCH, TACTILE (TUNER)	
S116	1-771-410-21	SWITCH, TACTILE (VIDEO 2)	
S117	1-771-410-21	SWITCH, TACTILE (BASS -)	
S118	1-771-410-21	SWITCH, TACTILE (SOUND FIELD MODE)	
S119	1-771-410-21	SWITCH, TACTILE (PRESET/PTY SELECT +)	(AEP,UK)
S119	1-771-410-21	SWITCH, TACTILE (PRESET TUNING +)	(EXCEPT AEP,UK)
S120	1-771-410-21	SWITCH, TACTILE (FM/AM)	(AEP,UK)
S120	1-771-410-21	SWITCH, TACTILE (FM)	(EXCEPT AEP,UK)
S121	1-771-410-21	SWITCH, TACTILE (SHIFT)	
S122	1-771-410-21	SWITCH, TACTILE (FM MODE)	
S123	1-771-410-21	SWITCH, TACTILE (MENU >)	
S124	1-771-410-21	SWITCH, TACTILE (MENU <)	
S125	1-771-410-21	SWITCH, TACTILE (PTY)	(AEP,UK)
S125	1-771-410-21	SWITCH, TACTILE (AM)	(EXCEPT AEP,UK)
S126	1-771-410-21	SWITCH, TACTILE (MEMORY)	
S127	1-771-410-21	SWITCH, TACTILE (TUNING +)	
S128	1-771-410-21	SWITCH, TACTILE (MENU +)	
S130	1-771-410-21	SWITCH, TACTILE (TREBLE -)	
S131	1-771-410-21	SWITCH, TACTILE (DVD/LD)	
S132	1-771-410-21	SWITCH, TACTILE (CINEMA STUDIO EX C)	
S133	1-771-410-21	SWITCH, TACTILE (CINEMA STUDIO EX B)	
S134	1-771-410-21	SWITCH, TACTILE (CINEMA STUDIO EX A)	
S135	1-771-410-21	SWITCH, TACTILE (BASS +)	
S136	1-771-410-21	SWITCH, TACTILE (SOUND FIELD A.F.D.)	
S137	1-771-410-21	SWITCH, TACTILE (SOUND FIELD 2CH)	
*****			
	1-683-763-11	HEADPHONE BOARD	*****
< CAPACITOR >			
C790	1-164-159-11	CERAMIC 0.1uF	50V
< CONNECTOR >			
CNP791	1-691-766-11	PLUG (MICRO CONNECTOR) 4P	
< JACK >			
J791	1-815-313-21	JACK (PHONES) (CH,SP,TW)	
J791	1-815-314-21	JACK (PHONES) (EXCEPT CH,SP,TW)	
*****			

Ref. No.	Part No.	Description	Remark	Ref. No.	Part No.	Description	Remark
A-4727-811-A		MAIN BOARD, COMPLETE (US)		C483	1-126-964-11	ELECT	10uF 20% 50V
A-4727-836-A		MAIN BOARD, COMPLETE (CND)		C484	1-126-964-11	ELECT	10uF 20% 50V
A-4727-848-A		MAIN BOARD, COMPLETE (AEP,UK)		C485	1-126-964-11	ELECT	10uF 20% 50V
A-4727-998-A		MAIN BOARD, COMPLETE (E,MX,AR)		C486	1-126-964-11	ELECT	10uF 20% 50V
A-4728-004-A		MAIN BOARD, COMPLETE (CH)		C487	1-126-964-11	ELECT	10uF 20% 50V
A-4728-861-A		MAIN BOARD, COMPLETE (AUS,SP,TW)		C488	1-164-159-11	CERAMIC	0.1uF 50V
		*****		C489	1-128-809-11	CERAMIC	100PF 5% 50V
				C490	1-128-809-11	CERAMIC	100PF 5% 50V
7-685-646-79		SCREW +BVTP 3X8 TYPE2 IT-3		C491	1-126-964-11	ELECT	10uF 20% 50V
		< CAPACITOR >		C492	1-126-964-11	ELECT	10uF 20% 50V
C371	1-161-494-00	CERAMIC	0.022uF 25V	C493	1-126-964-11	ELECT	10uF 20% 50V
C372	1-161-494-00	CERAMIC	0.022uF 25V	C494	1-126-964-11	ELECT	10uF 20% 50V
C373	1-161-494-00	CERAMIC	0.022uF 25V	C495	1-126-964-11	ELECT	10uF 20% 50V
C374	1-164-159-11	CERAMIC	0.1uF 50V	C496	1-126-963-11	ELECT	4.7uF 20% 50V
C375	1-161-494-00	CERAMIC	0.022uF 25V	C497	1-128-809-11	CERAMIC	100PF 5% 50V
C376	1-161-494-00	CERAMIC	0.022uF 25V	C498	1-162-211-31	CERAMIC	33PF 5% 50V
C402	1-126-964-11	ELECT	10uF 20% 50V	C501	1-126-963-11	ELECT	4.7uF 20% 50V
C404	1-126-964-11	ELECT	10uF 20% 50V	C503	1-104-665-11	ELECT	100uF 20% 10V
C405	1-126-964-11	ELECT	10uF 20% 50V	C504	1-107-583-11	CERAMIC	3PF 0.25PF 500V
C406	1-126-964-11	ELECT	10uF 20% 50V	C505	1-101-810-00	CERAMIC	100PF 5% 500V
C407	1-126-964-11	ELECT	10uF 20% 50V	C506	1-101-810-00	CERAMIC	100PF 5% 500V
C408	1-126-964-11	ELECT	10uF 20% 50V	C507	1-128-809-11	CERAMIC	100PF 5% 50V
C409	1-126-964-11	ELECT	10uF 20% 50V	C510	1-126-947-11	ELECT	47uF 20% 25V
C411	1-126-961-11	ELECT	2.2uF 20% 50V	C511	1-136-157-00	FILM	0.022uF 5% 50V
C412	1-126-961-11	ELECT	2.2uF 20% 50V	C516	1-162-815-11	CERAMIC	47PF 5% 500V
C413	1-126-964-11	ELECT	10uF 20% 50V	C517	1-162-815-11	CERAMIC	47PF 5% 500V
C414	1-126-964-11	ELECT	10uF 20% 50V	C519	1-128-813-11	CERAMIC	220PF 5% 50V
C415	1-124-261-00	ELECT	10uF 20% 50V	C540	1-126-964-11	ELECT	10uF 20% 50V
C416	1-126-964-11	ELECT	10uF 20% 50V	C541	1-127-876-11	CERAMIC	0.01uF 10% 50V
C417	1-124-261-00	ELECT	10uF 20% 50V	C601	1-126-963-11	ELECT	4.7uF 20% 50V
C418	1-126-964-11	ELECT	10uF 20% 50V	C603	1-104-665-11	ELECT	100uF 20% 10V
C419	1-126-964-11	ELECT	10uF 20% 50V	C604	1-107-583-11	CERAMIC	3PF 0.25PF 500V
C431	1-126-961-11	ELECT	2.2uF 20% 50V	C605	1-102-233-00	CERAMIC	33PF 10% 500V
C432	1-126-961-11	ELECT	2.2uF 20% 50V	C606	1-128-813-11	CERAMIC	220PF 5% 50V
C433	1-126-964-11	ELECT	10uF 20% 50V	C607	1-128-809-11	CERAMIC	100PF 5% 50V
C452	1-126-964-11	ELECT	10uF 20% 50V	C610	1-126-947-11	ELECT	47uF 20% 25V
C454	1-126-964-11	ELECT	10uF 20% 50V	C611	1-136-157-00	FILM	0.022uF 5% 50V
C455	1-126-964-11	ELECT	10uF 20% 50V	C616	1-106-355-12	MYLAR	0.0033uF 5% 200V
C456	1-126-964-11	ELECT	10uF 20% 50V	C617	1-106-355-12	MYLAR	0.0033uF 5% 200V
C457	1-126-964-11	ELECT	10uF 20% 50V	C619	1-128-813-11	CERAMIC	220PF 5% 50V
C458	1-126-964-11	ELECT	10uF 20% 50V	C620	1-162-815-11	CERAMIC	47PF 5% 500V
C459	1-126-964-11	ELECT	10uF 20% 50V	C621	1-162-815-11	CERAMIC	47PF 5% 500V
C461	1-126-961-11	ELECT	2.2uF 20% 50V	C640	1-126-964-11	ELECT	10uF 20% 50V
C462	1-126-961-11	ELECT	2.2uF 20% 50V	C642	1-127-876-11	CERAMIC	0.01uF 10% 50V
C464	1-164-159-11	CERAMIC	0.1uF 50V	C651	1-126-963-11	ELECT	4.7uF 20% 50V
C465	1-126-969-11	ELECT	220uF 20% 50V	C653	1-104-665-11	ELECT	100uF 20% 10V
C466	1-126-964-11	ELECT	10uF 20% 50V	C654	1-107-583-11	CERAMIC	3PF 0.25PF 500V
C467	1-164-159-11	CERAMIC	0.1uF 50V	C655	1-102-233-00	CERAMIC	33PF 10% 500V
C471	1-126-963-11	ELECT	4.7uF 20% 50V	C656	1-128-813-11	CERAMIC	220PF 5% 50V
C472	1-126-963-11	ELECT	4.7uF 20% 50V	C657	1-128-809-11	CERAMIC	100PF 5% 50V
C481	1-126-964-11	ELECT	10uF 20% 50V	C660	1-126-947-11	ELECT	47uF 20% 25V
C482	1-126-964-11	ELECT	10uF 20% 50V	C661	1-136-157-00	FILM	0.022uF 5% 50V
				C666	1-162-815-11	CERAMIC	47PF 5% 500V

# STR-DE485/DE485E

## MAIN

Ref. No.	Part No.	Description	Remark
C669	1-162-815-11	CERAMIC	47PF 5% 500V
C670	1-128-813-11	CERAMIC	220PF 5% 50V
C680	1-126-964-11	ELECT	10uF 20% 50V
C681	1-127-876-11	CERAMIC	0.01uF 10% 50V
C691	1-164-159-11	CERAMIC	0.1uF 50V
C701	1-126-963-11	ELECT	4.7uF 20% 50V
C703	1-104-665-11	ELECT	100uF 20% 10V
C704	1-107-583-11	CERAMIC	3PF 0.25PF 500V
C705	1-102-233-00	CERAMIC	33PF 10% 500V
C706	1-128-813-11	CERAMIC	220PF 5% 50V
C707	1-128-809-11	CERAMIC	100PF 5% 50V
C710	1-126-947-11	ELECT	47uF 20% 25V
C711	1-136-157-00	FILM	0.022uF 5% 50V
C716	1-162-815-11	CERAMIC	47PF 5% 500V
C717	1-162-815-11	CERAMIC	47PF 5% 500V
C720	1-128-813-11	CERAMIC	220PF 5% 50V
C721	1-126-934-11	ELECT	220uF 20% 10V
C722	1-126-964-11	ELECT	10uF 20% 50V
C732	1-128-582-11	ELECT	10uF 20% 100V
C733	1-128-582-11	ELECT	10uF 20% 100V
C740	1-126-964-11	ELECT	10uF 20% 50V
C741	1-128-579-11	ELECT	2.2uF 20% 100V
C742	1-127-876-11	CERAMIC	0.01uF 10% 50V
C750	1-126-964-11	ELECT	10uF 20% 50V
C751	1-126-963-11	ELECT	4.7uF 20% 50V
C752	1-127-876-11	CERAMIC	0.01uF 10% 50V
C753	1-104-665-11	ELECT	100uF 20% 10V
C754	1-107-583-11	CERAMIC	3PF 0.25PF 500V
C755	1-102-233-00	CERAMIC	33PF 10% 500V
C756	1-128-813-11	CERAMIC	220PF 5% 50V
C757	1-128-809-11	CERAMIC	100PF 5% 50V
C760	1-126-947-11	ELECT	47uF 20% 25V
C761	1-136-157-00	FILM	0.022uF 5% 50V
C766	1-162-815-11	CERAMIC	47PF 5% 500V
C767	1-162-815-11	CERAMIC	47PF 5% 500V
C770	1-128-813-11	CERAMIC	220PF 5% 50V
C801	1-126-947-11	ELECT	47uF 20% 35V
C802	1-126-947-11	ELECT	47uF 20% 35V
C803	1-165-498-11	ELECT	4700uF 20% 63V (EXCEPT CH) (CH)
C803	1-165-707-11	ELECT	10000uF 20% 71V (CH)
C804	1-165-498-11	ELECT	4700uF 20% 63V (EXCEPT CH)
C804	1-165-707-11	ELECT	10000uF 20% 71V (CH)
C805	1-135-851-21	MYLAR	0.22uF 100V
C806	1-135-851-21	MYLAR	0.22uF 100V
C807	1-104-665-11	ELECT	100uF 20% 10V
C808	1-104-665-11	ELECT	100uF 20% 10V
C810	1-164-159-11	CERAMIC	0.1uF 50V
C811	1-164-159-11	CERAMIC	0.1uF 50V
C820	1-164-159-11	CERAMIC	0.1uF 50V
C821	1-164-159-11	CERAMIC	0.1uF 50V

Ref. No.	Part No.	Description	Remark
C822	1-126-947-11	ELECT	47uF 20% 35V
C830	1-164-159-11	CERAMIC	0.1uF 50V
C901	1-164-159-11	CERAMIC	0.1uF 50V
C903	1-126-936-11	ELECT	3300uF 20% 16V
CC02	1-128-809-11	CERAMIC	100PF 5% 50V (AEP,UK,CH)
CC04	1-128-809-11	CERAMIC	100PF 5% 50V (AEP,UK,CH)
CC05	1-128-809-11	CERAMIC	100PF 5% 50V (AEP,UK,CH)
CC07	1-128-809-11	CERAMIC	100PF 5% 50V
CC12	1-127-876-21	CERAMIC	0.01uF 10% 50V
CC14	1-127-876-21	CERAMIC	0.01uF 10% 50V
CC16	1-127-876-21	CERAMIC	0.01uF 10% 50V
CC18	1-127-876-21	CERAMIC	0.01uF 10% 50V
CC20	1-127-876-21	CERAMIC	0.01uF 10% 50V
CC57	1-128-809-11	CERAMIC	100PF 5% 50V
< CONNECTOR >			
* CN792	1-564-706-11	PIN, CONNECTOR (SMALL TYPE) 4P	
CNP501	1-573-847-11	CONNECTOR, BOARD TO BOARD 15P	
CNP502	1-784-038-21	CONNECTOR, BOARD TO BOARD 9P	
* CNP801	1-564-104-00	PIN, CONNECTOR (B3P-VH) 3P	
CNP802	1-691-767-11	PLUG (MICRO CONNECTOR) 5P	
CNP911	1-784-928-11	PIN, CONNECTOR 13P	
CNP915	1-766-200-11	SOCKET, CONNECTOR 5P	
< DIODE >			
D505	8-719-911-19	DIODE 1SS119-25	
D510	8-719-911-19	DIODE 1SS119-25	
D540	8-719-911-19	DIODE 1SS119-25	
D560	8-719-911-19	DIODE 1SS119-25	
D605	8-719-911-19	DIODE 1SS119-25	
D610	8-719-911-19	DIODE 1SS119-25	
D640	8-719-911-19	DIODE 1SS119-25	
D665	8-719-911-19	DIODE 1SS119-25	
D680	8-719-911-19	DIODE 1SS119-25	
D690	8-719-934-21	DIODE HZS30-1L	
D691	8-719-911-19	DIODE 1SS119-25	
D705	8-719-911-19	DIODE 1SS119-25	
D710	8-719-911-19	DIODE 1SS119-25	
D721	8-719-911-19	DIODE 1SS119-25	
D722	8-719-911-19	DIODE 1SS119-25	
D731	8-719-911-19	DIODE 1SS119-25	
D732	8-719-911-19	DIODE 1SS119-25	
D733	8-719-911-19	DIODE 1SS119-25	
D734	8-719-911-19	DIODE 1SS119-25	
D740	8-719-911-19	DIODE 1SS119-25	
D750	8-719-911-19	DIODE 1SS119-25	
D765	8-719-911-19	DIODE 1SS119-25	
D791	8-719-911-19	DIODE 1SS119-25	
D801	8-719-934-21	DIODE HZS30-1L	
D802	8-719-072-05	DIODE RBV-602LF-A	

Ref. No.	Part No.	Description	Remark	Ref. No.	Part No.	Description	Remark
D804	8-719-118-63	DIODE RD5.6F-T7B2		Q640	8-729-281-53	TRANSISTOR 2SC1815-GR	
D896	8-719-043-76	DIODE AK04V0		Q651	8-729-119-76	TRANSISTOR 2SA1175-HFE	
D902	8-719-024-99	DIODE 11ES2-NTA2B		Q652	8-729-141-30	TRANSISTOR 2SC3623A-LK	
D903	8-719-024-99	DIODE 11ES2-NTA2B		Q655	8-729-140-82	TRANSISTOR 2SA988-PAFAEA	
D904	8-719-024-99	DIODE 11ES2-NTA2B		Q656	8-729-140-82	TRANSISTOR 2SA988-PAFAEA	
D905	8-719-024-99	DIODE 11ES2-NTA2B		Q680	8-729-281-53	TRANSISTOR 2SC1815-GR	
		< IC >		Q691	8-729-281-53	TRANSISTOR 2SC1815-GR	
IC201	8-759-827-92	IC M61511FP		Q692	8-729-900-63	TRANSISTOR DTA124ES	
IC401	8-759-636-74	IC M5218AP-22		Q701	8-729-119-76	TRANSISTOR 2SA1175-HFE	
IC501	8-749-011-16	IC STK350-230		Q702	8-729-141-30	TRANSISTOR 2SC3623A-LK	
IC601	8-759-636-74	IC M5218AP-22		Q705	8-729-140-82	TRANSISTOR 2SA988-PAFAEA	
IC701	6-700-943-01	IC uPC2581V-S		Q706	8-729-140-82	TRANSISTOR 2SA988-PAFAEA	
IC702	6-700-943-01	IC uPC2581V-S		Q710	8-729-119-79	TRANSISTOR 2SC2785-FEK	
IC801	8-759-649-68	IC uPC78M07AHF		Q722	8-729-140-84	TRANSISTOR 2SC1841-PAFAEA	
IC802	8-759-604-95	IC M5F79M07L		Q723	8-729-119-79	TRANSISTOR 2SC2785-FEK	
		< JACK >		Q725	8-729-140-82	TRANSISTOR 2SA988-PAFAEA	
J401	1-779-380-11	JACK, PIN 6P (MULTI CH IN FRONT/ SURROUND/CENTER/SUB WOOFER)		Q740	8-729-281-53	TRANSISTOR 2SC1815-GR	
J402	1-770-614-11	JACK, PIN 4P (CD IN,MD/TAPE OUT)		Q747	8-729-900-63	TRANSISTOR DTA124ES	
J403	1-770-614-11	JACK, PIN 4P (MD/TAPE IN,DVD/LD AUDIO IN)		Q748	8-729-900-36	TRANSISTOR DTC124ES	
J404	1-779-380-11	JACK, PIN 6P (VIDEO 2 AUDIO IN, VIDEO 1 AUDIO OUT/AUDIO IN)		Q750	8-729-281-53	TRANSISTOR 2SC1815-GR	
J405	1-774-843-11	JACK, PIN 1P (SUB WOOFER AUDIO OUT)		Q751	8-729-119-76	TRANSISTOR 2SA1175-HFE	
		< COIL >		Q752	8-729-141-30	TRANSISTOR 2SC3623A-LK	
L521	1-422-009-13	COIL, AIR-CORE		Q755	8-729-140-82	TRANSISTOR 2SA988-PAFAEA	
L601	1-422-009-13	COIL, AIR-CORE		Q756	8-729-140-82	TRANSISTOR 2SA988-PAFAEA	
L651	1-422-009-13	COIL, AIR-CORE		Q790	8-729-119-79	TRANSISTOR 2SC2785-FEK	
L701	1-422-009-13	COIL, AIR-CORE		Q801	8-729-140-97	TRANSISTOR 2SB734-34	
L751	1-422-009-13	COIL, AIR-CORE				< RESISTOR >	
		< TRANSISTOR >		R360	1-249-441-11	CARBON 100K 5% 1/4W	
Q361	8-729-823-22	TRANSISTOR 2SC3576		R361	1-249-425-11	CARBON 4.7K 5% 1/4W	
Q362	8-729-823-22	TRANSISTOR 2SC3576		R362	1-249-425-11	CARBON 4.7K 5% 1/4W	
Q363	8-729-823-22	TRANSISTOR 2SC3576		R363	1-249-441-11	CARBON 100K 5% 1/4W	
Q364	8-729-823-22	TRANSISTOR 2SC3576		R366	1-249-429-11	CARBON 10K 5% 1/4W	
Q365	8-729-823-22	TRANSISTOR 2SC3576		R367	1-249-441-11	CARBON 100K 5% 1/4W	
Q366	8-729-823-22	TRANSISTOR 2SC3576		R368	1-249-437-11	CARBON 47K 5% 1/4W	
Q379	8-729-900-63	TRANSISTOR DTA124ES		R369	1-249-425-11	CARBON 4.7K 5% 1/4W	
Q471	8-729-823-22	TRANSISTOR 2SC3576		R370	1-249-425-11	CARBON 4.7K 5% 1/4W	
Q501	8-729-119-76	TRANSISTOR 2SA1175-HFE		R371	1-249-441-11	CARBON 100K 5% 1/4W	
Q502	8-729-141-30	TRANSISTOR 2SC3623A-LK		R372	1-249-441-11	CARBON 100K 5% 1/4W	
Q505	8-729-140-82	TRANSISTOR 2SA988-PAFAEA		R373	1-249-417-11	CARBON 1K 5% 1/4W	
Q506	8-729-140-82	TRANSISTOR 2SA988-PAFAEA		R374	1-249-417-11	CARBON 1K 5% 1/4W	
Q540	8-729-281-53	TRANSISTOR 2SC1815-GR		R375	1-249-417-11	CARBON 1K 5% 1/4W	
Q550	8-729-119-79	TRANSISTOR 2SC2785-FEK		R376	1-249-417-11	CARBON 1K 5% 1/4W	
Q560	8-729-119-79	TRANSISTOR 2SC2785-FEK		R377	1-249-417-11	CARBON 1K 5% 1/4W	
Q505	8-729-140-82	TRANSISTOR 2SA988-PAFAEA		R378	1-249-417-11	CARBON 1K 5% 1/4W	
Q506	8-729-140-82	TRANSISTOR 2SA988-PAFAEA		R379	1-249-425-11	CARBON 4.7K 5% 1/4W	
Q540	8-729-281-53	TRANSISTOR 2SC1815-GR		R380	1-249-441-11	CARBON 100K 5% 1/4W	
Q550	8-729-119-79	TRANSISTOR 2SC2785-FEK		R381	1-249-429-11	CARBON 10K 5% 1/4W	
Q560	8-729-119-79	TRANSISTOR 2SC2785-FEK		R402	1-249-417-11	CARBON 1K 5% 1/4W	
Q601	8-729-119-76	TRANSISTOR 2SA1175-HFE		R404	1-249-417-11	CARBON 1K 5% 1/4W	
Q602	8-729-141-30	TRANSISTOR 2SC3623A-LK		R405	1-249-417-11	CARBON 1K 5% 1/4W	
Q605	8-729-140-82	TRANSISTOR 2SA988-PAFAEA		R406	1-249-417-11	CARBON 1K 5% 1/4W	
Q606	8-729-140-82	TRANSISTOR 2SA988-PAFAEA		R407	1-249-417-11	CARBON 1K 5% 1/4W	
Q610	8-729-119-79	TRANSISTOR 2SC2785-FEK					

# STR-DE485/DE485E

## MAIN

Ref. No.	Part No.	Description			Remark	Ref. No.	Part No.	Description			Remark
R408	1-249-417-11	CARBON	1K	5%	1/4W	R514	1-249-405-11	CARBON	100	5%	1/4W
R409	1-249-417-11	CARBON	1K	5%	1/4W	R515	1-249-405-11	CARBON	100	5%	1/4W
R411	1-249-417-11	CARBON	1K	5%	1/4W	R516	1-233-352-41	COMPONENT, ENCAPSULATED 0.22X2			
R412	1-249-417-11	CARBON	1K	5%	1/4W	R517	1-249-393-11	CARBON	10	5%	1/4W
R413	1-249-437-11	CARBON	47K	5%	1/4W	R520	1-249-425-11	CARBON	4.7K	5%	1/4W
R414	1-249-437-11	CARBON	47K	5%	1/4W	R521	1-247-850-11	CARBON	6.2K	5%	1/4W
R415	1-249-437-11	CARBON	47K	5%	1/4W	R522	1-249-419-11	CARBON	1.5K	5%	1/4W
R416	1-249-437-11	CARBON	47K	5%	1/4W	R524	1-249-431-11	CARBON	15K	5%	1/4W
R417	1-249-437-11	CARBON	47K	5%	1/4W	R525	1-249-439-11	CARBON	68K	5%	1/4W
R418	1-249-437-11	CARBON	47K	5%	1/4W	R528	1-249-389-11	CARBON	4.7	5%	1/4W
R419	1-249-437-11	CARBON	47K	5%	1/4W	R531	1-249-425-11	CARBON	4.7K	5%	1/4W
R420	1-249-437-11	CARBON	47K	5%	1/4W	R532	1-249-425-11	CARBON	4.7K	5%	1/4W
R422	1-249-437-11	CARBON	47K	5%	1/4W	R533	1-249-437-11	CARBON	47K	5%	1/4W
R424	1-249-437-11	CARBON	47K	5%	1/4W	R534	1-249-389-11	CARBON	4.7	5%	1/4W
R425	1-249-437-11	CARBON	47K	5%	1/4W	R540	1-249-433-11	CARBON	22K	5%	1/4W
R426	1-249-437-11	CARBON	47K	5%	1/4W	R546	1-247-843-11	CARBON	3.3K	5%	1/4W
R427	1-249-437-11	CARBON	47K	5%	1/4W	R555	1-249-433-11	CARBON	22K	5%	1/4W
R431	1-249-417-11	CARBON	1K	5%	1/4W	R556	1-249-433-11	CARBON	22K	5%	1/4W
R432	1-249-417-11	CARBON	1K	5%	1/4W	R557	1-249-431-11	CARBON	15K	5%	1/4W
R435	1-249-437-11	CARBON	47K	5%	1/4W	R560	1-249-429-11	CARBON	10K	5%	1/4W
R436	1-249-437-11	CARBON	47K	5%	1/4W	R573	1-249-437-11	CARBON	47K	5%	1/4W
R442	1-249-437-11	CARBON	47K	5%	1/4W	R601	1-249-417-11	CARBON	1K	5%	1/4W
R444	1-249-437-11	CARBON	47K	5%	1/4W	R602	1-249-439-11	CARBON	68K	5%	1/4W
R445	1-249-437-11	CARBON	47K	5%	1/4W	R603	1-249-415-11	CARBON	680	5%	1/4W
R446	1-249-437-11	CARBON	47K	5%	1/4W	R604	1-249-439-11	CARBON	68K	5%	1/4W
R447	1-249-437-11	CARBON	47K	5%	1/4W	R610	1-249-421-11	CARBON	2.2K	5%	1/4W
R452	1-249-417-11	CARBON	1K	5%	1/4W	R611	1-249-440-11	CARBON	82K	5%	1/4W
R454	1-249-417-11	CARBON	1K	5%	1/4W	R613	1-249-414-11	CARBON	560	5%	1/4W
R455	1-249-417-11	CARBON	1K	5%	1/4W	R614	1-249-405-11	CARBON	100	5%	1/4W
R456	1-249-417-11	CARBON	1K	5%	1/4W	R615	1-249-405-11	CARBON	100	5%	1/4W
R457	1-249-417-11	CARBON	1K	5%	1/4W	R616	1-233-352-41	COMPONENT, ENCAPSULATED 0.22X2			
R458	1-249-417-11	CARBON	1K	5%	1/4W	R617	1-249-393-11	CARBON	10	5%	1/4W
R459	1-249-417-11	CARBON	1K	5%	1/4W	R618	1-249-389-11	CARBON	4.7	5%	1/4W
R461	1-249-417-11	CARBON	1K	5%	1/4W	R620	1-249-425-11	CARBON	4.7K	5%	1/4W
R462	1-249-417-11	CARBON	1K	5%	1/4W	R621	1-247-850-11	CARBON	6.2K	5%	1/4W
R463	1-249-437-11	CARBON	47K	5%	1/4W	R622	1-249-419-11	CARBON	1.5K	5%	1/4W
R464	1-249-437-11	CARBON	47K	5%	1/4W	R623	1-249-437-11	CARBON	47K	5%	1/4W
R469	1-249-417-11	CARBON	1K	5%	1/4W	R624	1-249-431-11	CARBON	15K	5%	1/4W
R470	1-249-437-11	CARBON	47K	5%	1/4W	R625	1-249-439-11	CARBON	68K	5%	1/4W
R471	1-249-417-11	CARBON	1K	5%	1/4W	R631	1-249-425-11	CARBON	4.7K	5%	1/4W
R472	1-249-417-11	CARBON	1K	5%	1/4W	R634	1-249-389-11	CARBON	4.7	5%	1/4W
R473	1-249-421-11	CARBON	2.2K	5%	1/4W	R638	1-249-439-11	CARBON	68K	5%	1/4W
R474	1-249-432-11	CARBON	18K	5%	1/4W	R640	1-249-433-11	CARBON	22K	5%	1/4W
R475	1-249-421-11	CARBON	2.2K	5%	1/4W	R648	1-247-843-11	CARBON	3.3K	5%	1/4W
R499	1-249-437-11	CARBON	47K	5%	1/4W	R651	1-249-417-11	CARBON	1K	5%	1/4W
R501	1-249-417-11	CARBON	1K	5%	1/4W	R652	1-249-439-11	CARBON	68K	5%	1/4W
R502	1-249-439-11	CARBON	68K	5%	1/4W	R653	1-249-415-11	CARBON	680	5%	1/4W
R503	1-249-415-11	CARBON	680	5%	1/4W	R654	1-249-439-11	CARBON	68K	5%	1/4W
R504	1-249-411-11	CARBON	330	5%	1/4W	R655	1-249-433-11	CARBON	22K	5%	1/4W
R505	1-249-439-11	CARBON	68K	5%	1/4W	R656	1-249-433-11	CARBON	22K	5%	1/4W
R510	1-249-421-11	CARBON	2.2K	5%	1/4W	R657	1-249-431-11	CARBON	15K	5%	1/4W
R511	1-249-440-11	CARBON	82K	5%	1/4W	R660	1-249-421-11	CARBON	2.2K	5%	1/4W
R513	1-249-414-11	CARBON	560	5%	1/4W	R661	1-249-440-11	CARBON	82K	5%	1/4W



Ref. No.	Part No.	Description	Remark	Ref. No.	Part No.	Description	Remark
R663	1-249-414-11	CARBON	560 5% 1/4W	R744	1-249-433-11	CARBON	22K 5% 1/4W
R664	1-249-405-11	CARBON	100 5% 1/4W	R745	1-249-433-11	CARBON	22K 5% 1/4W
R665	1-249-405-11	CARBON	100 5% 1/4W	R746	1-249-433-11	CARBON	22K 5% 1/4W
R666	1-233-352-41	COMPONENT, ENCAPSULATED 0.22X2		R747	1-249-431-11	CARBON	15K 5% 1/4W
R667	1-249-393-11	CARBON	10 5% 1/4W	R748	1-247-843-11	CARBON	3.3K 5% 1/4W
R668	1-249-389-11	CARBON	4.7 5% 1/4W	R750	1-249-433-11	CARBON	22K 5% 1/4W
R669	1-249-425-11	CARBON	4.7K 5% 1/4W	R751	1-249-417-11	CARBON	1K 5% 1/4W
R671	1-247-850-11	CARBON	6.2K 5% 1/4W	R752	1-249-439-11	CARBON	68K 5% 1/4W
R672	1-249-419-11	CARBON	1.5K 5% 1/4W	R753	1-249-415-11	CARBON	680 5% 1/4W
R673	1-249-437-11	CARBON	47K 5% 1/4W	R754	1-249-439-11	CARBON	68K 5% 1/4W
R674	1-249-431-11	CARBON	15K 5% 1/4W	R755	1-249-433-11	CARBON	22K 5% 1/4W
R675	1-249-433-11	CARBON	22K 5% 1/4W	R756	1-249-433-11	CARBON	22K 5% 1/4W
R676	1-249-433-11	CARBON	22K 5% 1/4W	R757	1-249-431-11	CARBON	15K 5% 1/4W
R677	1-249-431-11	CARBON	15K 5% 1/4W	R758	1-247-843-11	CARBON	3.3K 5% 1/4W
R680	1-249-433-11	CARBON	22K 5% 1/4W	R760	1-249-421-11	CARBON	2.2K 5% 1/4W
R681	1-247-843-11	CARBON	3.3K 5% 1/4W	R761	1-249-440-11	CARBON	82K 5% 1/4W
R690	1-247-887-00	CARBON	220K 5% 1/4W	R763	1-249-414-11	CARBON	560 5% 1/4W
△ R691	1-215-888-00	METAL OXIDE	220 5% 2W F	R764	1-249-405-11	CARBON	100 5% 1/4W
△ R692	1-215-889-00	METAL OXIDE	330 5% 2W F	R765	1-249-405-11	CARBON	100 5% 1/4W
R693	1-249-429-11	CARBON	10K 5% 1/4W	R766	1-233-352-41	COMPONENT, ENCAPSULATED 0.22X2	
R694	1-249-429-11	CARBON	10K 5% 1/4W	R767	1-249-393-11	CARBON	10 5% 1/4W
R695	1-249-429-11	CARBON	10K 5% 1/4W	R768	1-249-389-11	CARBON	4.7 5% 1/4W
R696	1-249-436-11	CARBON	39K 5% 1/4W	R769	1-249-425-11	CARBON	4.7K 5% 1/4W
R698	1-249-429-11	CARBON	10K 5% 1/4W	R770	1-249-437-11	CARBON	47K 5% 1/4W
R699	1-247-895-11	CARBON	470K 5% 1/4W	R771	1-247-850-11	CARBON	6.2K 5% 1/4W
R701	1-249-417-11	CARBON	1K 5% 1/4W	R772	1-249-419-11	CARBON	1.5K 5% 1/4W
R702	1-249-439-11	CARBON	68K 5% 1/4W	R773	1-249-437-11	CARBON	47K 5% 1/4W
R703	1-249-415-11	CARBON	680 5% 1/4W	R775	1-249-439-11	CARBON	68K 5% 1/4W
R704	1-249-439-11	CARBON	68K 5% 1/4W	R778	1-249-431-11	CARBON	15K 5% 1/4W
R710	1-249-421-11	CARBON	2.2K 5% 1/4W	R780	1-249-429-11	CARBON	10K 5% 1/4W
R711	1-249-440-11	CARBON	82K 5% 1/4W	R791	1-249-425-11	CARBON	4.7K 5% 1/4W
R713	1-249-414-11	CARBON	560 5% 1/4W	△ R792	1-215-868-00	METAL OXIDE	680 5% 1W F
R714	1-249-405-11	CARBON	100 5% 1/4W	R793	1-249-389-11	CARBON	4.7 5% 1/4W
R715	1-249-405-11	CARBON	100 5% 1/4W	△ R794	1-215-868-00	METAL OXIDE	680 5% 1W F
R716	1-233-352-41	COMPONENT, ENCAPSULATED 0.22X2		R802	1-249-381-11	CARBON	1 5% 1/4W
R717	1-249-393-11	CARBON	10 5% 1/4W	R803	1-249-389-11	CARBON	4.7 5% 1/4W
R718	1-249-389-11	CARBON	4.7 5% 1/4W	R804	1-249-426-11	CARBON	5.6K 5% 1/4W
R719	1-249-425-11	CARBON	4.7K 5% 1/4W	R806	1-249-433-11	CARBON	22K 5% 1/4W
R721	1-247-850-11	CARBON	6.2K 5% 1/4W	△ R910	1-243-635-11	FUSIBLE	0.33 5% 1/2W F
R722	1-249-419-11	CARBON	1.5K 5% 1/4W	RR11	1-249-393-11	CARBON	10 5% 1/4W
R723	1-249-437-11	CARBON	47K 5% 1/4W	RR12	1-249-393-11	CARBON	10 5% 1/4W
R724	1-249-431-11	CARBON	15K 5% 1/4W	RR13	1-249-393-11	CARBON	10 5% 1/4W
R725	1-249-439-11	CARBON	68K 5% 1/4W	RR14	1-249-393-11	CARBON	10 5% 1/4W
R731	1-249-425-11	CARBON	4.7K 5% 1/4W	RR15	1-249-393-11	CARBON	10 5% 1/4W
R732	1-249-381-11	CARBON	1 5% 1/4W			< RELAY >	
R733	1-249-381-11	CARBON	1 5% 1/4W				
R734	1-249-389-11	CARBON	4.7 5% 1/4W	RY501	1-755-421-11	RELAY (12V)	
R735	1-249-427-11	CARBON	6.8K 5% 1/4W	RY560	1-755-267-11	RELAY	
R736	1-249-417-11	CARBON	1K 5% 1/4W	RY601	1-755-421-11	RELAY (12V)	
R737	1-249-436-11	CARBON	39K 5% 1/4W	RY701	1-755-421-11	RELAY (12V)	
R740	1-249-433-11	CARBON	22K 5% 1/4W	RY791	1-755-421-11	RELAY (12V)	
R742	1-249-437-11	CARBON	47K 5% 1/4W				
R743	1-249-433-11	CARBON	22K 5% 1/4W				

The components identified by mark △ or dotted line with mark △ are critical for safety. Replace only with part number specified.

Les composants identifiés par une marque △ sont critiques pour la sécurité. Ne les remplacer que par une pièce portant le numéro spécifié.

以阴影和 △ 标志来识别的零部件，在安全方面具有关键性，因此只能以规定号码的零部件来更换。

# STR-DE485/DE485E

<b>MAIN</b>	<b>POWER SW</b>	<b>STANDBY</b>
-------------	-----------------	----------------

Ref. No.	Part No.	Description	Remark
< TERMINAL BOARD >			
TM601	1-537-510-11	TERMINAL BOARD (6P) (SPEAKERS SURROUND/CENTER)	
TM602	1-537-925-61	TERMINAL BOARD (4P) (SPEAKERS FRONT)	
*****			
	1-683-759-11	POWER SW BOARD	*****
< CONNECTOR >			
CNP104	1-691-766-11	PLUG (MICRO CONNECTOR) 4P	
< RESISTOR >			
R138	1-249-433-11	CARBON	22K 5% 1/4W
R139	1-249-437-11	CARBON	47K 5% 1/4W
< SWITCH >			
S143	1-771-410-21	SWITCH, TACTILE (DISPLAY)	
S144	1-771-410-21	SWITCH, TACTILE (DIMMER)	
S145	1-771-410-21	SWITCH, TACTILE (I/⊙)	
*****			
A-4727-816-A	STANDBY BOARD, COMPLETE (US)		
A-4727-841-A	STANDBY BOARD, COMPLETE (CND)		
A-4727-850-A	STANDBY BOARD, COMPLETE (AEP,UK,CH,AR)		
A-4727-969-A	STANDBY BOARD, COMPLETE (AUS,SP)		
A-4727-995-A	STANDBY BOARD, COMPLETE (MX)		
A-4728-005-A	STANDBY BOARD, COMPLETE (E)		
A-4728-869-A	STANDBY BOARD, COMPLETE (TW)		
*****			
	1-533-293-11	HOLDER, FUSE	
< CAPACITOR >			
C813	1-164-159-11	CERAMIC	0.1uF 50V
C814	1-164-159-11	CERAMIC	0.1uF 50V
C815	1-126-943-11	ELECT	2200uF 20% 25V
C816	1-126-941-11	ELECT	470uF 20% 25V
C898	1-126-949-11	ELECT	220uF 20% 35V
C899	1-126-948-11	ELECT	100uF 20% 35V
C920	1-164-159-11	CERAMIC	0.1uF 50V
C921	1-164-159-11	CERAMIC	0.1uF 50V
C923	1-126-959-11	ELECT	0.47uF 20% 50V
C950	1-126-936-11	ELECT	3300uF 20% 16V
< CONNECTOR >			
CNP901	1-564-321-00	PIN, CONNECTOR 2P	
* CNP902	1-565-792-11	PIN, CONNECTOR 2P	
CNP903	1-564-506-11	PLUG, CONNECTOR 3P	
CNP905	1-766-203-11	PLUG, CONNECTOR (PC BOARD) 5P	
CNP906	1-784-921-11	PIN, CONNECTOR 4P (E)	
CNP912	1-784-921-11	PIN, CONNECTOR 4P	

Ref. No.	Part No.	Description	Remark
< DIODE >			
D820	8-719-024-99	DIODE	11ES2-NTA2B
D821	8-719-024-99	DIODE	11ES2-NTA2B
D822	8-719-024-99	DIODE	11ES2-NTA2B
D823	8-719-024-99	DIODE	11ES2-NTA2B
D898	8-719-024-99	DIODE	11ES2-NTA2B
D899	8-719-024-99	DIODE	11ES2-NTA2B
D901	8-719-911-19	DIODE	1SS119-25
D910	8-719-024-99	DIODE	11ES2-NTA2B
D911	8-719-024-99	DIODE	11ES2-NTA2B
D912	8-719-024-99	DIODE	11ES2-NTA2B
D913	8-719-024-99	DIODE	11ES2-NTA2B
D914	8-719-911-19	DIODE	1SS119-25
D915	8-719-911-19	DIODE	1SS119-25
< EARTH TERMINAL >			
* G901	1-537-738-21	TERMINAL, EARTH	
< TRANSISTOR >			
Q901	8-729-119-79	TRANSISTOR	2SC2785-FEK
Q921	8-729-281-53	TRANSISTOR	2SC1815-GR
< RESISTOR >			
△ R810	1-240-877-11	FUSIBLE	0.15 5% 1/2W F
△ R811	1-240-877-11	FUSIBLE	0.15 5% 1/2W F
△ R812	1-240-877-11	FUSIBLE	0.15 5% 1/2W F
△ R901	1-219-237-11	SOLID	3.3M 20% 1/2W F (US,CND)
R902	1-249-437-11	CARBON	47K 5% 1/4W
R903	1-249-425-11	CARBON	4.7K 5% 1/4W
R904	1-249-381-11	CARBON	1 5% 1/4W
R921	1-249-437-11	CARBON	47K 5% 1/4W
R922	1-249-435-11	CARBON	33K 5% 1/4W
R923	1-249-429-11	CARBON	10K 5% 1/4W
< RELAY >			
△ RY901	1-755-334-11	RELAY, AC POWER (9V)	
< TRANSFORMER >			
△ T902	1-435-434-11	TRANSFORMER, POWER (E)	
△ T902	1-435-435-11	TRANSFORMER, POWER (AEP,UK,AUS,CH,SP,AR)	
△ T902	1-435-436-11	TRANSFORMER, POWER (US,CND,MX)	
△ T902	1-435-563-11	TRANSFORMER, POWER (TW)	
*****			

The components identified by mark △ or dotted line with mark △ are critical for safety. Replace only with part number specified.	Les composants identifiés par une marque △ sont critiques pour la sécurité. Ne les remplacer que par une pièce portant le numéro spécifié.	以阴影和 △ 标志来识别的零部件，在安全方面具有关键性。因此只能以规定号码的零部件来更换。
--	--	---

Ref. No.	Part No.	Description	Remark	Ref. No.	Part No.	Description	Remark
	A-4727-815-A	VIDEO BOARD, COMPLETE (US)				MISCELLANEOUS	
	A-4727-840-A	VIDEO BOARD, COMPLETE (CND,MX)				*****	
	A-4727-849-A	VIDEO BOARD, COMPLETE (AEP,UK,E,CH,AR)					
	A-4727-968-A	VIDEO BOARD, COMPLETE (AUS,SP,TW)					
		*****					
	7-685-646-79	SCREW +BVTP 3X8 TYPE2 IT-3		53	1-773-250-11	WIRE (FLAT TYPE) (27 CORE)	
		< CAPACITOR >		△ 105	1-696-847-11	CORD, POWER (AUS)	
C200	1-128-805-11	CERAMIC	47PF 5% 50V	△ 105	1-769-744-11	CORD, POWER (AEP,UK)	
C201	1-128-805-11	CERAMIC	47PF 5% 50V	△ 105	1-777-071-21	CORD, POWER (E,SP,TW)	
C206	1-126-964-11	ELECT	10uF 20% 50V	△ 105	1-783-205-11	CORD, POWER (CH)	
C207	1-126-964-11	ELECT	10uF 20% 50V				
C208	1-126-964-11	ELECT	10uF 20% 50V	△ 105	1-783-820-11	CORD, POWER (US,CND,MX)	
C209	1-126-960-11	ELECT	1uF 20% 50V	△ 105	1-783-941-12	CORD, POWER (AR)	
C210	1-126-964-11	ELECT	10uF 20% 50V	106	1-769-940-11	WIRE (FLAT TYPE) (11 CORE) (EXCEPT AEP,UK)	
C213	1-126-964-11	ELECT	10uF 20% 50V	106	1-773-004-11	WIRE (FLAT TYPE) (15 CORE) (AEP,UK)	
C214	1-164-159-11	CERAMIC	0.1uF 50V	107	1-575-662-31	WIRE (FLAT TYPE) (5 CORE) (AUS,SP,TW)	
C215	1-164-159-11	CERAMIC	0.1uF 50V				
C248	1-128-825-11	CERAMIC	0.0022uF 5% 50V	107	1-769-844-11	WIRE (FLAT TYPE) (5 CORE) (EXCEPT AUS,SP,TW)	
C249	1-128-825-11	CERAMIC	0.0022uF 5% 50V	△ F901	1-532-464-31	FUSE (T2.5A/250V) (EXCEPT US,CND,MX,TW)	
C809	1-104-665-11	ELECT	100uF 20% 10V	△ F901	1-576-109-11	FUSE (5A/125V) (TW)	
C824	1-164-159-11	CERAMIC	0.1uF 50V	△ F901	1-576-193-11	FUSE (6.3A/125V) (US,CND,MX)	
C825	1-164-159-11	CERAMIC	0.1uF 50V	Q503	8-749-010-25	TRANSISTOR MN2488-OPY-M	
C827	1-126-947-11	ELECT	47uF 20% 25V	Q504	8-749-010-26	TRANSISTOR MP1620-OPY-M	
		< CONNECTOR >		Q603	8-749-010-25	TRANSISTOR MN2488-OPY-M	
CNP156	1-779-978-11	PIN, CONNECTOR 3P		Q604	8-749-010-26	TRANSISTOR MP1620-OPY-M	
CNS150	1-569-315-11	SOCKET, CONNECTOR 5P		Q653	8-749-010-25	TRANSISTOR MN2488-OPY-M	
		< DIODE >		Q654	8-749-010-26	TRANSISTOR MP1620-OPY-M	
D203	8-719-911-19	DIODE 1SS119-25		Q703	8-749-010-25	TRANSISTOR MN2488-OPY-M	
D204	8-719-911-19	DIODE 1SS119-25		Q704	8-749-010-26	TRANSISTOR MP1620-OPY-M	
		< IC >		Q753	8-749-010-25	TRANSISTOR MN2488-OPY-M	
IC103	6-701-890-01	IC NJM2595D		Q754	8-749-010-26	TRANSISTOR MP1620-OPY-M	
IC804	8-759-701-65	IC NJM79M05FA		△ T901	1-437-632-11	TRANSFORMER, POWER (US,MX)	
IC807	8-759-701-75	IC NJM7805FA		△ T901	1-437-633-11	TRANSFORMER, POWER (AEP,UK,CH,SP,AR)	
		< JACK >		△ T901	1-437-634-11	TRANSFORMER, POWER (CND)	
J200	1-770-337-11	JACK, PIN 3P (DVD/LD VIDEO IN, VIDEO 2 VIDEO IN,VIDEO 1 VIDEO OUT)		△ T901	1-437-635-11	TRANSFORMER, POWER (E)	
J201	1-695-317-11	JACK, PIN 2P (VIDEO 1 VIDEO IN, MONITOR VIDEO OUT)		△ T901	1-437-637-11	TRANSFORMER, POWER (AUS)	
		< RESISTOR >		△ T901	1-437-638-11	TRANSFORMER, POWER (TW)	
R200	1-247-804-11	CARBON	75 5% 1/4W	TM301	1-693-577-11	TUNER PACK (FM/AM) (ANTENNA) (E)	
R201	1-247-804-11	CARBON	75 5% 1/4W	TM301	1-693-577-21	TUNER PACK (FM/AM) (ANTENNA) (US,CND,MX,TW)	
R218	1-247-804-11	CARBON	75 5% 1/4W	TM301	1-693-578-21	TUNER PACK (FM/AM) (ANTENNA) (AEP,UK)	
R219	1-247-804-11	CARBON	75 5% 1/4W	TM301	1-693-580-21	TUNER PACK (FM/AM) (ANTENNA) (AUS,CH,SP,AR)	
R220	1-247-804-11	CARBON	75 5% 1/4W				
R221	1-247-804-11	CARBON	75 5% 1/4W				
*****							

The components identified by mark △ or dotted line with mark △ are critical for safety. Replace only with part number specified.

Les composants identifiés par une marque △ sont critiques pour la sécurité. Ne les remplacer que par une pièce portant le numéro spécifié.

以阴影和 △ 标志来识别的零部件，在安全方面具有关键性，因此只能以规定号码的零部件来更换。

# STR-DE485/DE485E

Ref. No.	Part No.	Description	Remark
		ACCESSORIES *****	
	1-477-204-11	REMOTE COMMANDER (RM-U306)	
	1-501-374-11	ANTENNA, LOOP (AM)	
	1-501-594-11	ANTENNA (FM) (AEP,UK,AUS,CH,SP,AR)	
△	1-569-008-21	ADAPTOR, CONVERSION 2P (E)	
△	1-770-019-11	ADAPTOR, CONVERSION PLUG 3P (UK)	
	1-793-184-21	CONNECTOR (F TYPE ADAPTOR) (US,CND,E,MX,TW)	
	4-228-696-01	COVER, BATTERY (for RM-U306)	
	4-238-376-11	MANUAL, INSTRUCTION (ENGLISH) (US,CND,AEP,UK, E,AUS,SP,TW)	
	4-238-376-21	MANUAL, INSTRUCTION (FRENCH) (CND,AEP,E,SP)	
	4-238-376-31	MANUAL, INSTRUCTION (SPANISH) (AEP,E,MX,SP)	
	4-238-376-41	MANUAL, INSTRUCTION (TRADITIONAL CHINESE) (E,SP,TW)	
	4-238-376-51	MANUAL, INSTRUCTION (ENGLISH, SIMPLIFIED CHINESE) (CH)	
	4-238-376-61	MANUAL, INSTRUCTION (ENGLISH,SPANISH) (AR)	
	4-238-376-71	MANUAL, INSTRUCTION (GERMAN,DUTCH, SWEDISH) (AEP)	
	4-238-376-81	MANUAL, INSTRUCTION (ITALIAN,POLISH) (AEP)	
	4-240-464-11	MANUAL, INSTRUCTION (DANISH,FINNISH) (AEP)	
	4-240-464-21	MANUAL, INSTRUCTION (PORTUGUESE) (AEP)	
	4-240-464-31	MANUAL, INSTRUCTION (RUSSIAN) (AEP)	

The components identified by mark △ or dotted line with mark △ are critical for safety. Replace only with part number specified.	Les composants identifiés par une marque △ sont critiques pour la sécurité. Ne les remplacer que par une pièce portant le numéro spécifié.	以阴影和 △ 标志来识别的零部件，在安全方面具有关键性。因此只能以规定号码的零部件来更换。
--	--	---

MEMO

